

SULIT
4541/1
Chemistry
Paper 1
September 2009
1¼ jam

PEPERIKSAAN PERCUBAAN SPM

CHEMISTRY

Kertas 1

Satu jam lima belas minit

JANGAN BUKA KERTAS SOALAN INI SEHINGGA DIBERITAHU
DO NOT OPEN THIS PAPER UNTIL YOU ARE TOLD TO DO SO

- 1. Kertas soalan ini adalah dalam dwibahasa.*
- 2. Soalan di bahagian atas adalah dalam Bahasa Inggeris. Soalan di bahagian bawah dalam tulisan condong adalah dalam Bahasa Malaysia yang sepadan.*
- 3. Calon dikehendaki membaca maklumat di halaman 2 atau halaman 3.*

Kertas soalan ini mengandungi 32 halaman bercetak

@PKPSM Pahang

[Lihat sebelah

INFORMATION FOR CANDIDATES

1. This question paper consists of 50 questions.
2. Answer **all** questions.
3. Answer each question by blackening the correct space on the answer sheet.
4. Blacken only **one** space for each question.
5. If you wish to change your answer, erase the blackened mark that you have made. Then blacken the space for the new answer.
6. The diagrams in the questions provided are not drawn to scale unless stated.
7. You may use a non-programmable scientific calculator.

MAKLUMAT UNTUK CALON

1. *Kertas soalan ini mengandungi 50 soalan.*
2. *Jawab **semua** soalan.*
3. *Jawab dengan menghitamkan ruangan yang betul pada kertas jawapan.*
4. *Hitamkan **satu** ruangan sahaja bagi setiap soalan.*
5. *Sekiranya anda hendak menukar jawapan, padamkan tanda yang telah dibuat. Kemudian hitamkan jawapan yang baru.*
6. *Rajah yang mengiringi soalan tidak dilukis mengikut skala kecuali dinyatakan.*
7. *Anda dibenarkan menggunakan kalkulator saintifik yang tidak boleh diprogram.*

- 1 A gas jar that contains air is placed on top of a gas jar of bromine. After a period of time, a uniform colour is observed throughout both gas jars. What process has happened?

Sebuah balang yang berisi udara diletakkan di atas sebuah lagi balang gas yang berisi bromin. Setelah beberapa ketika kedua-dua balang gas itu dipenuhi dengan suatu gas yang berwarna. Apakah proses yang berlaku?

- A Condensation
 Kondensasi
- B Evaporation
 Pemeruapan
- C Diffusion
 Peresapan
- D Sublimation
 Pemejalwapan
- 2 Diagram 2 show the symbol of an atom copper.
Rajah 2 menunjukkan simbol atom kuprum.

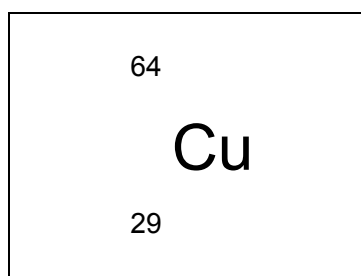

Diagram 2

Which of the following is correct based on the symbol in diagram 2.
Antara berikut yang manakah benar berdasarkan simbol dalam Rajah 2 ?

	Proton number <i>Nombor proton</i>	Nucleon number <i>Nombor nucleon</i>	Number of electron <i>Bilangan elektron</i>
A	29	64	29
B	35	29	64
C	64	35	29
D	29	64	35

3. Which of the following atomic models was proposed by Ernest Rutherford?
Antara berikut yang manakah model atom yang disyorkan oleh Ernest Rutherford?
- A The atom is the smallest particle.
Atom merupakan zarah terkecil.
- B The atom is a positively charged sphere.
Atom ialah sfera yang bercas positif.
- C The atom contains a nucleus that is surrounded by electrons moving a random.
Atom mengandungi satu nukleus yang dikelilingi oleh elektron yang bergerak secara rawak.
- D The atom contains a nucleus that is surrounded by electrons that move in certain orbitals.
Atom mengandungi satu nukleus yang dikelilingi oleh elektron yang bergerak dalam orbit yang tertentu.
- 3 From the position in the Periodic Table, we can predict many properties of an element and its compound. What property can not be predicted?
Berdasarkan posisi dalam Jadual Berkala, kita boleh meramalkan pelbagai sifat suatu unsur dan sebatianannya. Apakah sifat yang tidak boleh diramalkan?
- A The formula of its oxide.
Formula oksida.
- B The number of isotopes it has.
Bilangan isotop.
- C The melting point.
Takat lebur.
- D The freezing point.
Takat beku.
- 4 Among the following compounds, which one contains particles bonded by strong electrostatic forces?
Di antara sebatian berikut, yang manakah terdiri daripada zarah yang diikat oleh daya elektrostatik yang kuat.
- A Ammonia
Ammonia
- B Naphthalene
Naftalena
- C Carbon monoxide
Karbon monoksida
- D Sodium chloride
Natrium klorida
- 5 Which of the following has the same empirical formula as ethene, C_2H_4 ?
Yang mana antara berikut mempunyai formula empirik yang sama dengan etena, C_2H_4 ?
- A C_3H_7 B C_4H_{11} C C_5H_{11} D H_{12}

- 6 The molar mass of astatine is 210 g mol^{-1} . What is the relative atomic mass for astatine?

Jisim molar astatin ialah g mol^{-1} . Berapakah jisim atom relatif bagi astatin?

- A 100
B 110
C 210
D 120

- 7 Which of the following conducts electricity but does not undergo chemical changes?

Yang mana antara berikut boleh mengkonduksi elektrik tetapi tidak mengalami perubahan kimia?

- A Molten lead(II) chloride
Leburan plumbum(II) klorida
B Molten sulphur
Leburan sulfur
C Molten magnesium
Leburan magnesium
D Molten aluminium nitrate
Leburan aluminium nitrat

- 8 Diagram 9 shows the set up of apparatus for the electrolysis of copper(II) sulphate solution. Which of the following solutions can be used to replace copper(II) sulphate solution?

Rajah 9 menunjukkan susunan radas bagi elektrolisis larutan kuprum(II) sulfat. Yang manakah larutan berikut yang boleh digunakan untuk menggantikan larutan kuprum(II) sulfat?

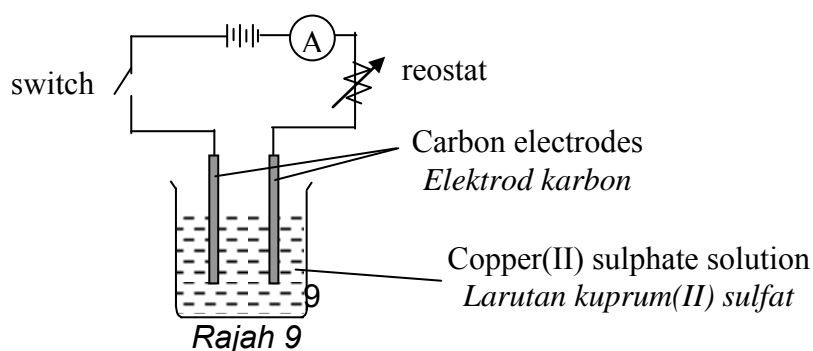

- A Ethyl ethanoate
Etil etanoat
B Potassium bromide solution
Larutan kalium bromida
C Hexane
Heksana
D Hexene
Heksena

- 9 Diagram 10 shows the set-up of apparatus for electrolysis.
Rajah 10 menunjukkan susunan radas untuk elektrolisis.

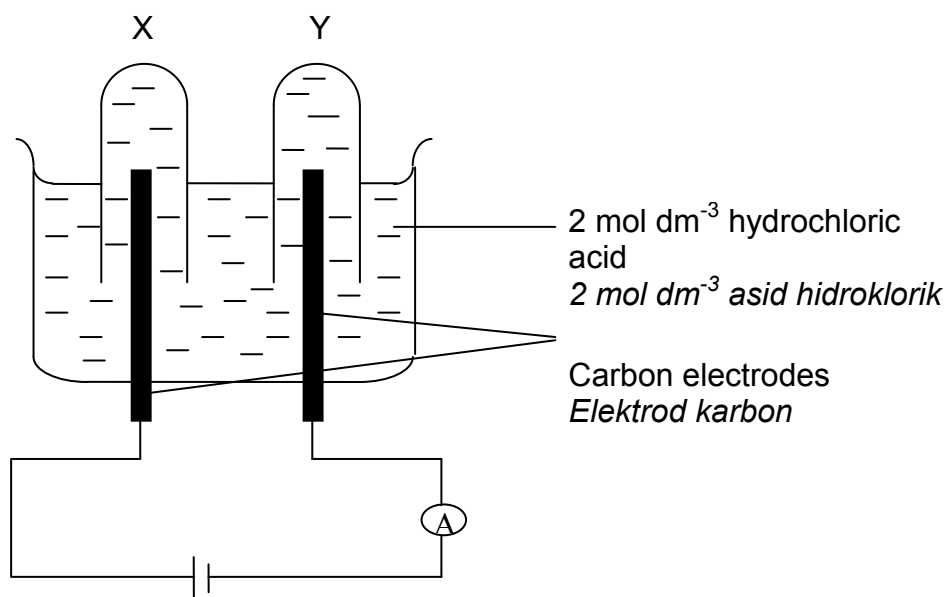

Diagram 10

What is test would you use to confirm the product formed in test tube Y after electrolysis has been carried out for some time?

Ujian apakah yang digunakan untuk mengesahkan hasil yang terbentuk dalam tabung uji Y selepas elektrolisis dijalankan?

- A A lighted wooden splinter
Kayu uji bermyala
- B Lime water
Air kapur
- C A glowing splinter
Kayu uji berbara
- D A moist litmus paper
Kertas litmus lembap
- 10 Which of the following is NOT TRUE about the properties of acid?
Yang mana antara berikut TIDAK BENAR tentang sifat asid?
- A Undergoes neutralisation with alkali.
Mengalami tindak balas peneutralan dengan alkali.
- B Has a pH value lower than 7.
Mempunyai nilai pH kurang daripada 7.
- C Reacts with ammonium salt and heated to produce ammonia gas.
Bertindak balas dengan garam ammonium semasa panas untuk menghasilkan gas ammonia.
- D Reacts with metal carbonates to produce hydrogen.
Bertindak balas dengan logam karbonat untuk menghasilkan hidrogen.

- 11 Latex can be kept in liquid state so that it can be transported to factories by adding

Lateks boleh dikekalkan dalam keadaan asal untuk diangkut ke kilang dengan menambah

- A ethanoic acid
asid etanoik
- B hydrochloric acid
asid hidroklorik
- C ammonium hydroxide
ammonium hidroksida
- D ammonium sulphate
ammonium sulfat

- 12 Which particle causes an aqueous solution of ammonia to exhibit alkaline properties?

Zarah yang manakah menyebabkan larutan ammonia akues memperlihatkan sifat-sifat alkali?

- A H_3O^+
- B OH^-
- C NH_4^+
- D NH_3

- 13 Which of the the following shows the arrangement of atoms in an alloy?
Yang mana antara berikut menunjukkan susunan atom dalam satu aloi?

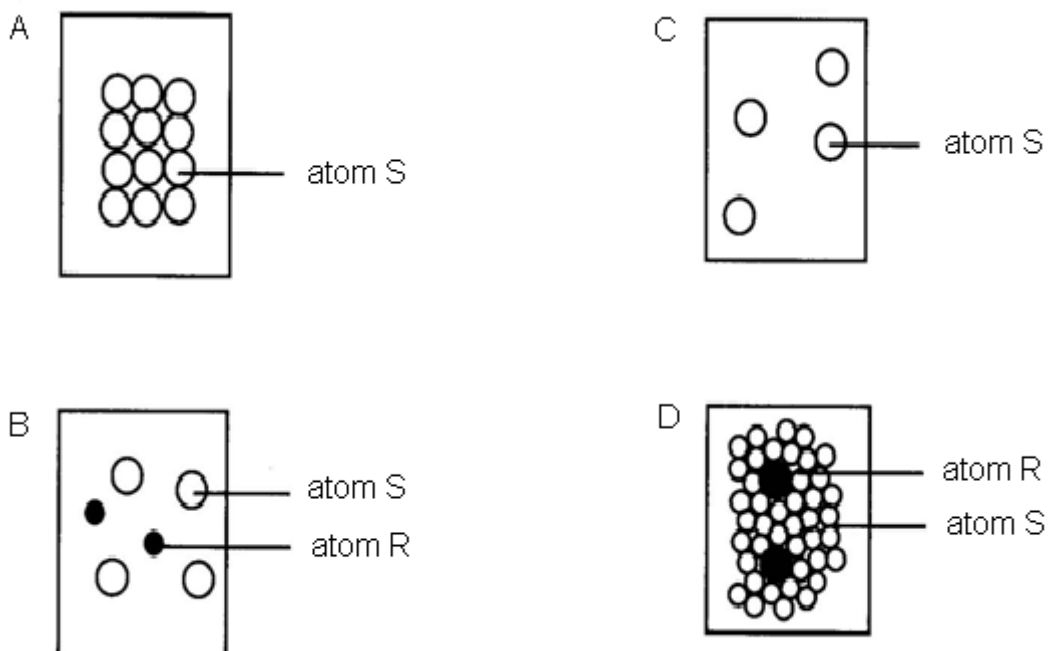

- 14 Diagram 15 shows a graph of a volume of gas against time. The rate of reaction is the highest at ...

Rajah 15 menunjukkan graf isipadu gas melawan masa. Kadar tindak balas yang paling tinggi adalah di ...

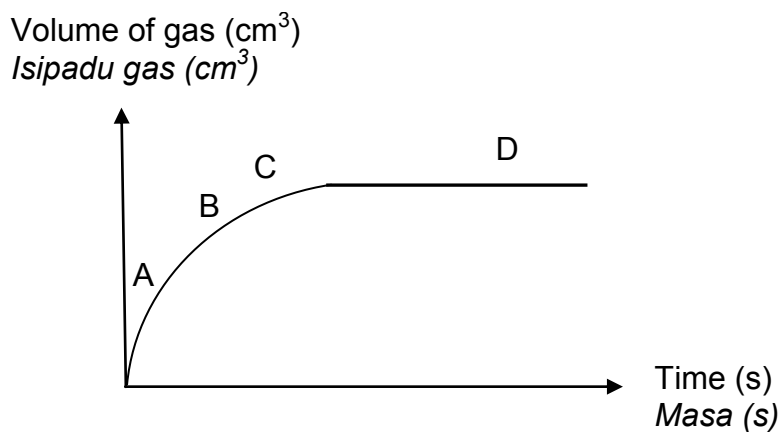
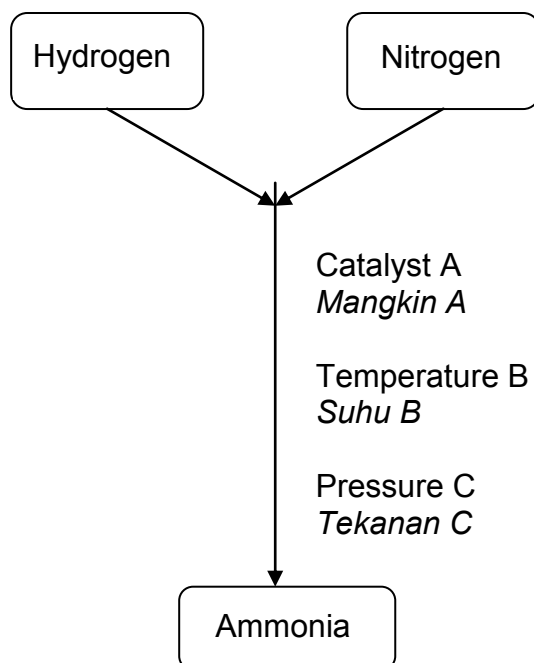

Diagram 15

- 15 The diagram below shows the formation of ammonia through Haber process. *Rajah di bawah menunjukkan penghasilan ammonia melalui proses Haber.*



Which of the following represent catalyst A, temperature B and pressure C?
 Yang manakah mewakili mangkin A, suhu B dan tekanan C?

	Catalyst Mangkin	Temperature B, °C Suhu B, °C	Pressure C, atm Tekanan, atm
A	Iron <i>Besi</i>	450	200
B	Platinum <i>Platinum</i>	450	100
C	Iron <i>Besi</i>	200	450
D	Vanadium(V) oxide <i>Vanadium(V) oksida</i>	550	200

- 16 A reaction between sodium thiosulphate solution and dilute sulphuric acid will produce sulphur. Which of the following graphs shows the relationship between the concentration of sodium thiosulphate solution and the time taken to form sulphur?

Tindak balas di antara larutan natrium tiosulfat dan larutan asid sulfurik akan menghasilkan sulfur. Yang manakah di antara graf berikut menunjukkan perhubungan di antara kepekatan larutan natrium tiosulfat dengan masa yang diambil untuk membentuk sulfur.

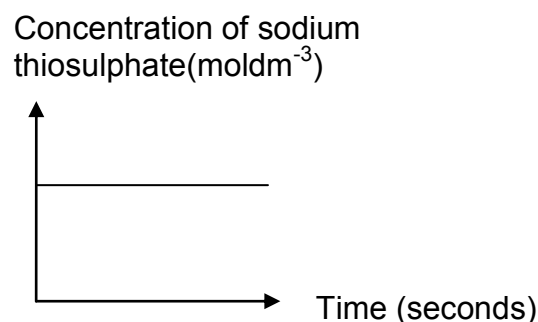
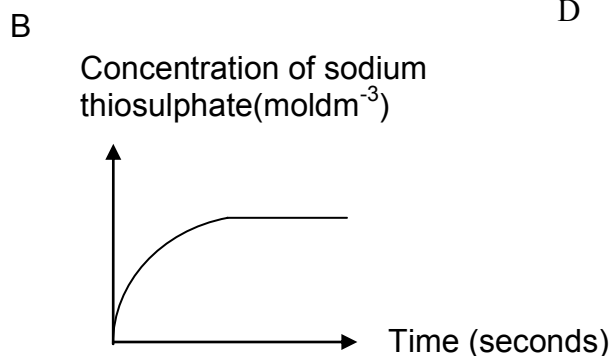
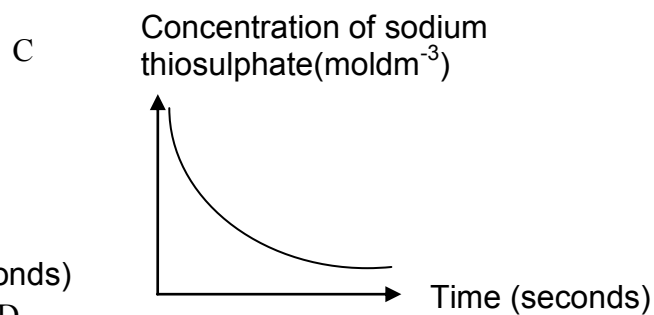
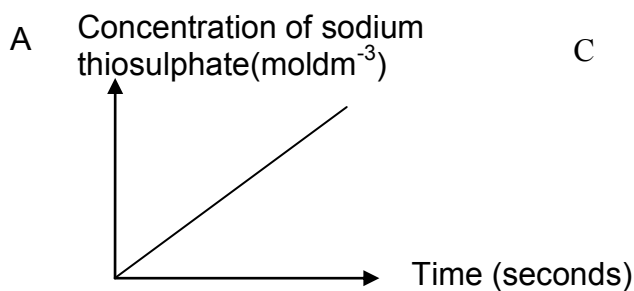

- 17 Which of the following is the function of an analgesic?
Yang mana antara berikut adalah fungsi analgesik?
- A To relieve pain
Melegakan kesakitan
 - B To treat asthma
Merawat asma
 - C To destroy bacteria
Membunuh bakteria
 - D To calm down the emotion of the patient
Menenangkan emosi pesakit
- 18 Heat energy is released when a fuel is burned in air. This is because ...
Tenaga haba dibebaskan semasa bahan api dibakar dalam udara. Ini kerana

- A energy is released when mixed with air.
haba dibebaskan semasa bercampur dengan udara.
 - B energy is released when chemical bonds are broken.
haba dibebaskan semasa ikatan dipecahkan.
 - C energy is released when new chemical bonds are formed.
haba dibebaskan semasa ikatan kimia baru terbentuk.
 - D energy is transformed from the chemicals.
haba dipindahkan daripada bahan kimia.
- 19 The heat of precipitation determined in the laboratory is less than theoretical value. Why?
Haba pemendakan yang dihitung di dalam makmal adalah kurang daripada nilai teori. Mengapa?
- A Some heat is absorbed by the thermometer.
Sebahagian haba diserap oleh termometer.
 - B Chemicals that are used contain impurities.
Bahan kimia yang digunakan mengandungi bendasing.
 - C Chemicals react with oxygen in the surrounding.
Bahan kimia bertindakbalas dengan oksigen di persekitaran.
 - D Heat is loss to surrounding.
Haba dibebas ke persekitaran.
- 20 An element M has proton number 12. It has the tendency of forming cation M^{2+} . What is the electron arrangement of M^{2+} ?
Unsur M mempunyai nombor proton 12. Ia cenderung membentuk kation M^{2+} . Apakah susunan elektron bagi M^{2+} ?
- A 2.8.2
 - B 2.2
 - C 2.8
 - D 2.8.8.2

- 21 Which of the following substances has INCORRECT chemical formulae?
 Yang manakah di antara sebatian berikut mempunyai formula kimia yang TIDAK BENAR?

	Substance <i>Bahan</i>	Formula <i>Formula</i>
A	Sodium chloride <i>Natrium klorida</i>	NaCl
B	Copper(II) sulphate <i>Kuprum(II) sulfat</i>	CuSO ₄
C	Potassium oxide <i>Kalium oksida</i>	K ₂ O
D	Ammonium nitrate <i>Ammonium nitrat</i>	NH ₄ (NO ₃) ₂

- 22 What is the number of oxygen atom in 0.1 mole of water?
 Apakah bilangan atom oksigen dalam 0.1 mol air?
 [Avogadro constant: $6.02 \times 10^{23} \text{ mol}^{-1}$]

- A 6.02×10^{22}
 B 6.02×10^{23}
 C 60.2×10^{23}
 D 3.01×10^{23}

- 23 Going down Group 18 of the Periodic Table of Element,
 Apabila menuruni Kumpulan 18 dalam Jadual Berkala Unsur,

- I the boiling point of the elements increases..
takat didih unsur bertambah.
 II the size of the atom increases.
saiz atom bertambah.
 III the forces of attraction between the particles increases.
daya tarikan di antara zarah bertambah.
 IV the solubility of the elements in water increases.
keterlarutan unsur dalam air bertambah.

- A I and II only
 B II and III only
 C III and IV only
 D I, II and III only

- Aluminium oxide reacts with hydrochloric acid
Aluminium oksida bertindak balas dengan asid hidroklorik
- Aluminium oxide reacts with sodium hydroxide solution
Aluminium oksida bertindak balas dengan larutan natrium hidroksida

24 The table above shows some information on aluminium oxide. From the information above, which of the following is TRUE?

Jadual di atas menunjukkan maklumat tentang aluminium oksida. Berdasarkan maklumat tersebut yang manakah BENAR?

- A Aluminium oxide is a base oxide.
Aluminium oksida ialah oksida bes.
- B Aluminium oxide is an acid oxide.
Aluminium oksida ialah oksida asid.
- C Aluminium oxide is an amphoteric oxide.
Aluminium oksida ialah oksida amfoterik.
- D Aluminium oxide is a metalloid oxide.
Aluminium oksida ialah oksida logam.

25 The diagram below shows the electron arrangement of atoms P, Q and R.
Rajah di bawah menunjukkan susunan electron bagi atom P, Q dan R.

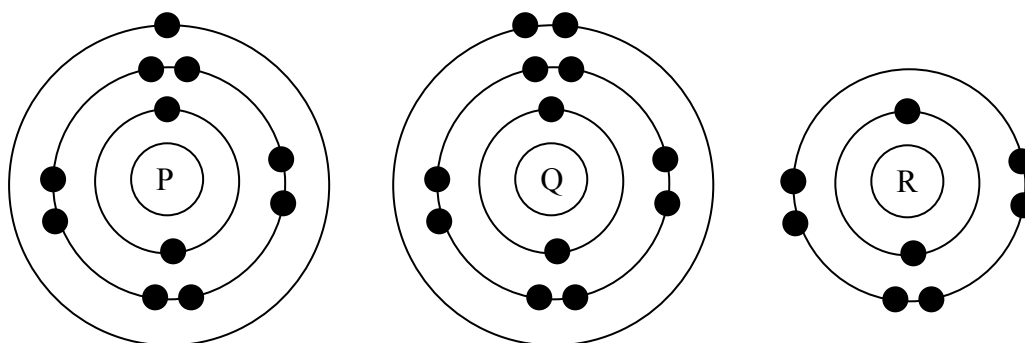

R can react with P and Q to form two different compounds. What are the formulae of the compounds formed?

R boleh bertindak balas dengan P dan Q membentuk dua sebatian berbeza. Apakah formula sebatian yang terbentuk?

	<u>P and R</u>	<u>Q and R</u>
A	P ₂ R	QR ₂
B	P ₂ R	QR
C	PR	QR ₂
D	PR ₂	QR ₂

26 When an electric current is flowed through molten lead(II) bromide, brown vapour can be seen on the anode of the carbon electrode. What is the reason?
Apabila arus elektrik dialirkan menerusi leburan plumbum(II) bromida, wasap perang boleh diperhatikan di anod elektrod karbon. Apakah sebabnya?

- A Potassium is formed at the anode.
Kalium terbentuk di anod.
- B Potassium reacts with bromine at the carbon anode.
Kalium bertindak balas di anod karbon.
- C Bromide ion loses electron at the carbon anode to produce bromine.
Ion bromida melepaskan elektron di anod karbon untuk menghasilkan bromine.
- D Potassium bromide dissociates into potassium ions and bromide ions.
Kalium bromida bercerai kepada ion kalium dan ion bromida.

27 Both ethanoic acid and nitric acid of concentration 1 mol dm⁻³ have ...
Kedua-dua asid etanoik dan asid nitric berkepekatan 1 mol dm⁻³ mempunyai ..

- I the same concentration of hydrogen ions
kepekatan ion hidrogen yang sama
 - II different degree of ionisation in water
darjah pengionan yang berbeza di dalam air
 - III different pH value
nilai pH yang berbeza
 - IV the same concentration of hydroxide ions
kepekatan ion hidroksida yang sama
- A I and II only
 - B II and III only
 - C III and IV only
 - D I and IV only

- 28 A student added solution P to solution Q. He then filter the mixture and obtained salt R as residue and solution S as filtrate. Which of the following equations correctly represent the preparation of salt R?

Seorang pelajar mencampur larutan P kepada larutan Q. Setelah itu dia menuras campuran tersebut dan memperoleh garam R sebagai baki turasan dan larutan S sebagai hasil turasan. Yang manakah persamaan yang betul bagi mewakili persediaan garam R?

- A $\text{HCl} + \text{NaOH} \rightarrow \text{NaCl} + \text{H}_2\text{O}$
 B $\text{CuCl}_2 + \text{Na}_2\text{SO}_4 \rightarrow \text{CuSO}_4 + 2\text{NaCl}$
 C $\text{MgCl}_2 + \text{Na}_2\text{CO}_3 \rightarrow \text{MgCO}_3 + 2\text{NaCl}$
 D $\text{CuSO}_4 + 2\text{KNO}_3 \rightarrow \text{Cu}(\text{NO}_3)_2 + \text{K}_2\text{SO}_4$

- 29 Below is an Energy Profile Diagram.

Di bawah ialah Rajah Profil Tenaga.

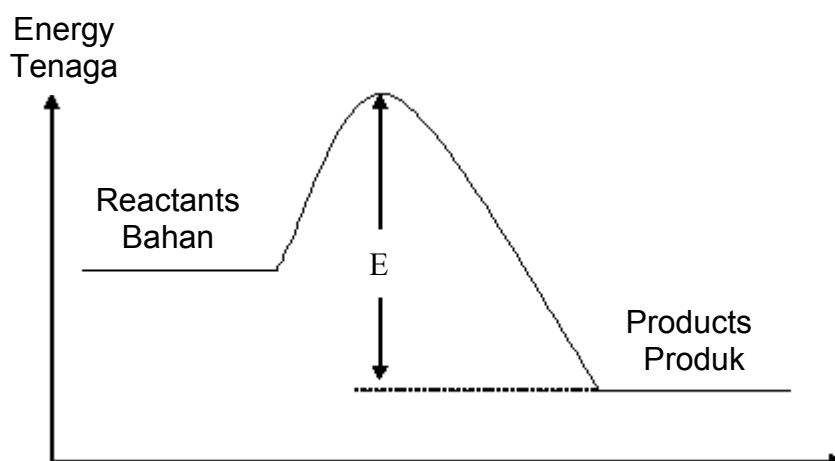

From the diagram above, it can be concluded that ...

Daripada rajah di atas, boleh disimpulkan bahawa...

- A heat is required to start the reaction.
haba diperlukan untuk memulakan tindak balas
- B the activation energy for the reaction is E.
tenaga pengaktifan ialah E.
- C the reaction is exothermic.
tindak balas berlaku ialah eksotermik.
- D the reactants are higher in concentration than the products.
kepekatan bahan adalah lebih tinggi daripada produk.

30 Study the structural formula below .

Kaji formula struktur di bawah.

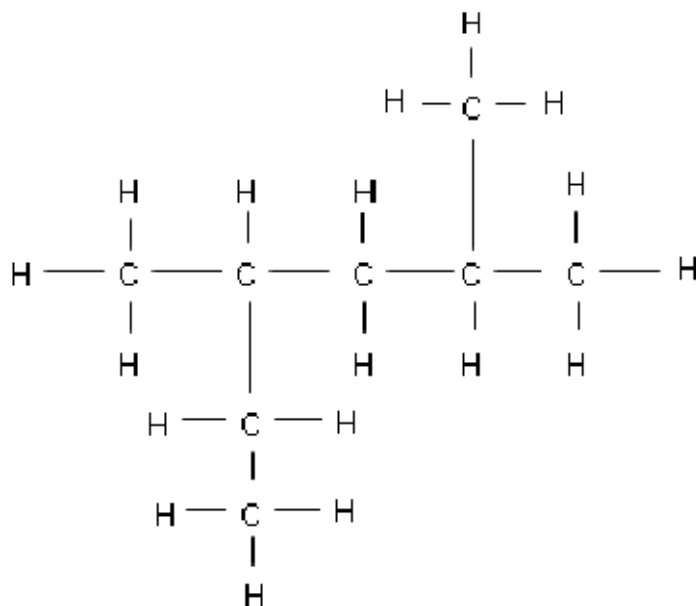

Based on the IUPAC system, what is the name of the compound having this structural formula?

Berdasarkan sistem IUPAC, apakah nama sebatian yang mempunyai formula struktur seperti itu?

- A 2,4,4- trimethylpentane
2,4,4-trimetilpentana
- B 2,4,4- trimethyloctane
2,4,4-trimetiloktana
- C 2-ethyl-4-methylpentane
2-etil-4-metilpentana
- D 2,4-dimethylhexane
2,4-dimetilheksana

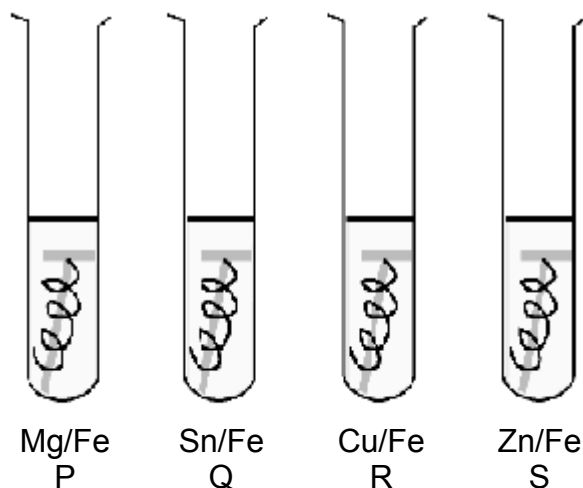

Diagram 32

- 31 Based on diagram 32 above, magnesium ribbon, tin foil, copper foil and zinc foil are coiled around four different iron nails. The metal pairs are then placed in a test tube containing aqueous sodium chloride solution. Which of the test tubes will contain the highest concentration of iron(II) ions after 2 days?

Merujuk kepada gambarajah 32 di atas, pita magnesium, lilitan stanum, lilitan ferum dan lilitan zink diikat pada paku besi. Pasangan logam itu kemudian diletakkan di dalam tabung uji yang mengandungi larutan natrium klorida. Antara tabung uji berikut yang manakah mengandungi kepekatan ion ferum(II) yang paling tinggi selepas 2 hari.

- A P
B Q
C R
D S

- 32 The heat of combustion of 1 mole of hexane can be determined by burning hexane in excess oxygen. Which of the following does **NOT** need to be taken when determining the heat of combustion?

Haba pembakaran bagi 1 mol heksana boleh dihitung dengan pembakaran heksana dalam oksigen berlebihan. Yang manakah antara berikut TIDAK diperlukan semasa menghitung haba pembakaran?

- A The initial and final temperatures of the water that is heated by the burning.
Suhu awal dan suhu akhir air semasa pemanasan.
- B The mass of the hexane used.
Jisim heksana yang digunakan.
- C The quantity of carbon dioxide released.
Kuantiti karbon dioksida yang dibebaskan.
- D The volume of water that is heated by the heat given out, when hexane is burnt. (Isipadu air yang dipanaskan semasa heksana dibakar.)

- 33 During the experiment to determine the heat of precipitation when silver nitrate solution is reacted with zinc chloride solution, the accuracy of the results is increased by ...

Semasa menjalankan eksperimen untuk menghitung haba pemendakan bagi silver nitrat yang bertindak balas dengan larutan zink klorida, ketepatan keputusan boleh dipertingkatkan dengan ...

- A conducting the experiment next to an open window.
menjalankan eksperimen berdekatan dengan tingkap terbuka.
- B using the thermometer to stir the mixture instead of a glass rod.
menggunakan termometer untuk mengacau campuran bagi menggantikan rod kaca.
- C using a ceramic cup instead of a polystyrene cup.
menggunakan cawan seramik bagi menggantikan cawan polisterena.
- D wrapping the polystyrene cup with aluminium foil.
membalut cawan polisterena dengan lingkaran aluminium.

34



Picture 35
Gambar 35

Picture 35 shows some oil palm fruits. Saponification of oil palm produces
Gambar 35 menunjukkan buah kelapa sawit. Saponifikasi minyak kelapa sawit menghasilkan

- A one glycerol molecule and one soap molecule.
satu molekul gliserol dan satu molekul sabun.
- B one glycerol molecule and two soap molecules.
satu molekul gliserol dan dua molekul sabun.
- C one glycerol molecule and three soap molecules.
satu molekul gliserol dan tiga molekul sabun.
- D soap and water molecules.
sabun dan molekul air.

35 The number of valence electrons in an atom of an element will determine ..
Bilangan elektron valens bagi satu atom unsur boleh menentukan ...

- I the stability of the atom.
kestabilan atom.
- II the chemical properties of the element.
sifat kimia unsur.
- III the group number of the element in the Periodic Table.
kumpulan unsur dalam Jadual Berkala.
- IV the melting point and boiling point of the element.
takat lebur dan takat didih unsur.

- A I and II only
- B I and III only
- C I, II and III only
- D I, II, III and IV

36 The chemical formula for glucose is $C_6H_{12}O_6$. This shows that ...
Formula kimia bagi glukos ialah $C_6H_{12}O_6$. Ini menunjukkan bahawa ...

- I the empirical formula for glucose is CH_2O .
formula empirik bagi glukos ialah CH_2O .
- II each glucose molecule is made up of 6 carbon atoms, 12 hydrogen atoms and 6 oxygen atoms.
setiap molekul glukosa terdiri daripada 6 atom karbon, 12 atom hidrogen dan 6 atom oksigen.
- III 1 mol of glucose contains a total of 144.48×10^{23} atoms.
1 mol glukosa mengandungi 144.48×10^{23} atom.
- IV one glucose molecule has a mass of 180 times higher than the mass of 1 hydrogen atom
satu molekul glukosa mempunyai jisim 180 kali lebih besar daripada jisim 1 atom hidrogen.

(Use the information relative atomic mass for H =1,C =12 and O =16
 Avogadro Constant = $6.02 \times 10^{23} \text{ mol}^{-1}$)

- A I and II only
- B I, III and IV only
- C II, III and IV only
- D I, II, III and IV

37

The relative atomic mass of metal K is 7 and the relative atomic mass of the metal L is 56.
Jisim atom relatif bagi logam K ialah 7 dan jisim atom relatif bagi logam L ialah 56.

Which of the following conclusions can be drawn from the above statement?
Yang manakah antara kesimpulan berikut menerangkan pernyataan di atas?

- I 1 mol of L has 8 times more atoms than 1 mol of K
1 mol L mempunyai 8 kali bilangan atom berbanding 1 mol K
 - II 1 atom of L is 8 times heavier than 1 atom of K
1 atom L adalah 8 kali lebih berat berbanding 1 atom K
 - III 1 atom of L has the same number of protons with 8 atoms of K
1 atom L mempunyai bilangan proton yang sama dengan 8 atom K
 - IV 56 g of L has the same number of atoms as in 7 g of K
56 g L mempunyai bilangan atom yang sama dengan 7 g K
- A** I and III only
B II and IV only
C I, II and III only
D I, II, III and IV

38 Diagram 39 shows set up apparatus for titration of potassium hydroxide with sulphuric acid.

Rajah 39 menunjukkan susunan radas bagi pentitratan larutan natrium hidroksida dengan asid sulfurik.

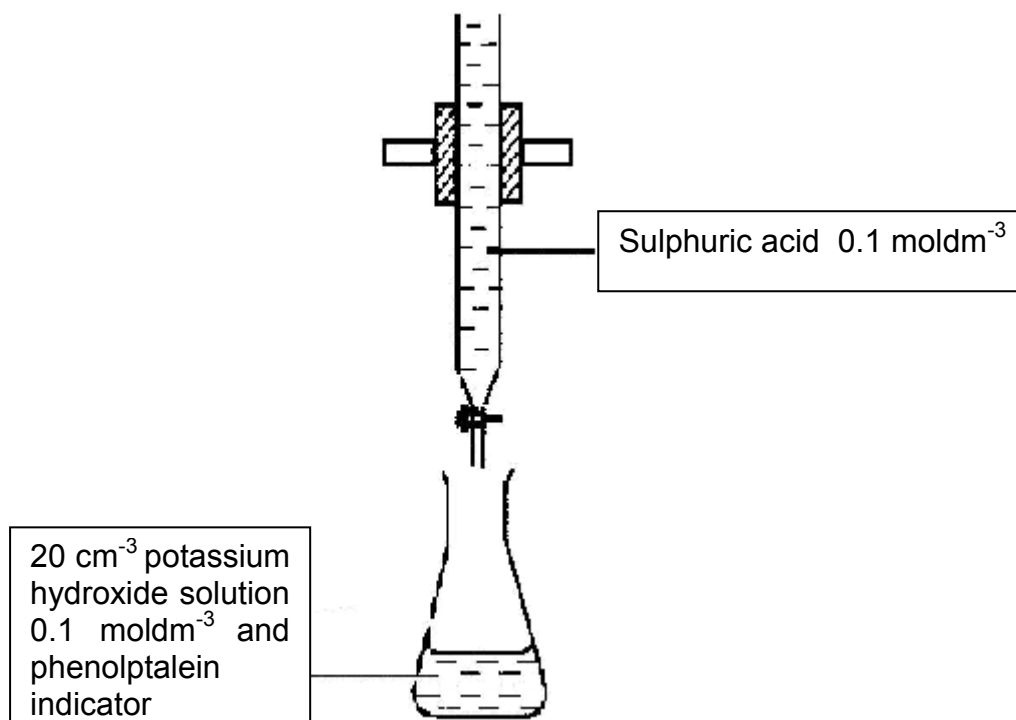

What is total volume of the mixed solution in the conical flask at the end point of titration in diagram 39?

Berapakah jumlah isipadu campuran di dalam kelalang kon pada takat akhir pentitratan dalam rajah 39 ?

- A 30 cm^3
- B 20 cm^3
- C 10 cm^3
- D 40 cm^3

- 39 Table 40 shows the total volume of carbon dioxide gas collected at various time interval in a reaction of calcium carbonate with hydrochloric acid.

Jadual 40 menunjukkan jumlah isipadu gas karbon dioksida yang terkumpul pada sela masa tertentu dalam suatu tindak balas antara kalsium karbonat dengan asid hidroklorik.

Time/ s Masa/s	0	30	60	90	120	150	180	210
Volume of gas/ cm^3 <i>Isipadu gas / cm^3</i>	0.00	4.20	7.70	10.90	13.70	15.20	16.00	16.00

Table 40

What is the average rate of reaction in the third minute?
Berapakah kadar tindak balas purata dalam minit kedua?

- A $0.128 \text{ cm}^3 \text{ s}^{-1}$
- B $0.100 \text{ cm}^3 \text{ s}^{-1}$
- C $0.114 \text{ cm}^3 \text{ s}^{-1}$
- D $0.088 \text{ cm}^3 \text{ s}^{-1}$

40 When a mixture of carbon and copper(II) oxide is heated strongly ...
Apabila satu campuran karbon dengan kuprum(II) oksida di panaskan dengan kuat ...

- I the oxide ion loses two electrons.
ion oksida melepaskan dua elektron.
- II the oxidation number of carbon increases from 0 to +4.
nombor pengoksidaan karbon bertambah dari 0 kepada +4.
- III the copper(II) oxide acts as the reducing agent.
kuprum(II) oksida bertindak sebagai agen penurunan.
- IV the copper(II) ion accepts two electrons.
ion kuprum(II) menerima dua elektron.

- A I and III only
- B II and IV only
- C II, III and IV only
- D I, II, III and IV

41 An esterification reaction is given as follows :

Tindak balas pengesteran adalah seperti berikut :

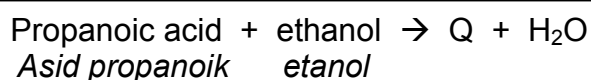

What is the molecular formula of ester Q?

Apakah formula molekul bagi ester Q?

- A $\text{C}_3\text{H}_7\text{COOC}_2\text{H}_5$
- B $\text{C}_2\text{H}_5\text{COOC}_3\text{H}_7$
- C $\text{C}_2\text{H}_5\text{COOC}_2\text{H}_5$
- D $\text{C}_5\text{H}_{11}\text{COOH}$

42

Positive terminal <i>Terminal positif</i>	Negative terminal <i>Terminal negatif</i>	Reading of the voltmeter/V <i>Bacaan voltmeter/V</i>
Lead <i>Plumbum</i>	Magnesium <i>Magnesium</i>	1.05
Zinc <i>Zink</i>	Magnesium <i>Magnesium</i>	0.42
Tin <i>Stanium</i>	Zinc <i>Zink</i>	0.51

Table 43

Table 43 shows the reading of a voltmeter for each pair of metals which are immersed in a electrolyte that are connected with one salt bridge to form a simple voltaic cell. From the results, what is the reading of the voltmeter of a voltaic cell that consists of a pair of lead and tin metals?

Jadual 43 menunjukkan bacaan voltmeter bagi setiap pasangan logam yang direndam dalam elektrolit yang dihubungkan dengan satu titian garam untuk membina satu sel voltan ringkas. Daripada jadual tersebut, apakah bacaan voltmeter bagi pasangan logam plumbum dan stanum?

- A 0.12 V
- B 0.63 V
- C 0.93 V
- D 1.98 V

- 43 An iron spoon is electroplated. The apparatus used is shown in diagram 44.
Satu sudu besi disadur. Radas digunakan ditunjuk dalam rajah 44.

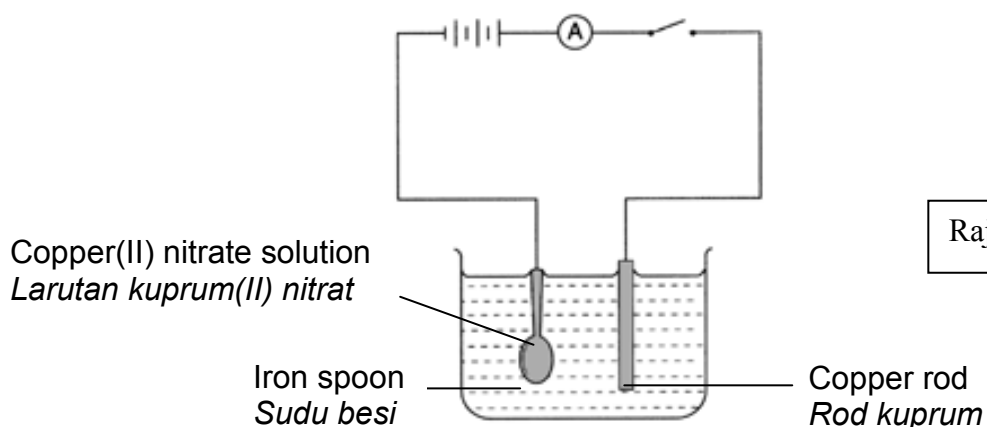

At the end of the electrolysis, it is observed that...
Setelah elektrolisis selesai, diperhatikan bahawa..

	Anode <i>Anod</i>	Cathode <i>Katod</i>
A	Brown deposits form <i>Enapan perang terbentuk</i>	Gas bubbles are released <i>Gelembung gas dibebaskan</i>
B	Copper rod becomes thinner <i>Rod kuprum menipis</i>	Brown deposits form <i>Enapan perang terbentuk</i>
C	Brown deposits form <i>Enapan perang terbentuk</i>	Copper rod becomes thicker <i>Rod kuprum menebal</i>
D	Gas bubbles are released <i>Gelembung gas dibebaskan</i>	Copper rod becomes thinner <i>Rod kuprum menipis</i>

- 44 The reaction between lead(II) nitrate and potassium iodide solution is represented by the equation below :

Tindak balas di antara larutan plumbum(II) nitrat dan larutan kalium iodida diwakili dengan persamaan di bawah :

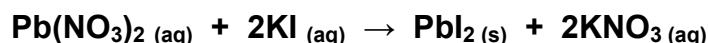

25.0 cm³ of 1.0 mol dm⁻³ potassium iodide solution is mixed with 25.0 cm³ of 1.0 mol dm⁻³ lead(II) nitrate solution. What is the maximum mass of lead(II) iodide produced in this reaction?

25.0 cm³ larutan kalium iodida 1.0 mol dm⁻³ dicampur dengan 25.0 cm³ larutan plumbum(II) nitrat 1.0 mol dm⁻³. Apakah jisim maksimum bagi plumbum(II) iodida yang terhasil dalam tindak balas tersebut.

(Use the information relative atomic mass for I = 127 and Pb = 207)

- A** 4.175 g
B 5.76 g
C 8.35 g
D 11.52 g

45

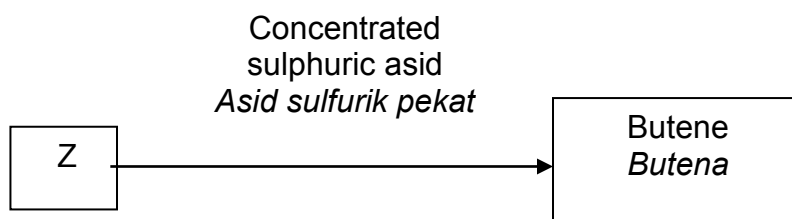

Diagram 46
Rajah 46

Consider the conversion in Diagram 46 and identify the substance Z.
Pertimbangkan pertukaran dalam Rajah 46 dan kenal pasti bahan Z

- A 1-butanol
1-butanol
- B 2-methylpropanol
2-metilpropanol
- C Butanoic acid
Asid butanoik
- D 2-methyl-2-butanol
2-metil-2-butanol
- 46 When 25 cm^3 of 0.25 mol dm^{-3} silver nitrate solution is added into 25 cm^3 of 0.25 mol dm^{-3} sodium chloride solution, the temperature of the mixture rises by 3°C . What is the quantity of heat released in this experiment?
Apabila 25 cm^3 of 0.25 mol dm^{-3} larutan argentum nitrat ditambah ke 25 cm^3 of 0.25 mol dm^{-3} larutan natrium klorida, suhu campuran tersebut meningkat sebanyak 3°C . Apakah kuantiti haba yang dibebaskan di dalam eksperimen ini.
- (Specific heat capacity of water = $4.2 \text{ J g}^{-1} \text{ }^\circ\text{C}^{-1}$)
(*Muatan haba tentu air = $4.2 \text{ J g}^{-1} \text{ }^\circ\text{C}^{-1}$*)
- A 315 J
- B 78.75 J
- C 630 J
- D 157.5 J

47 The following statements are about atom U and T.

Pernyataan berikut adalah mengenai atom U dan T.

- Electron arrangement of atom U is 1
Susunan elektron atom U ialah 1
- Proton number of atom T is 6
Nombor proton atom T ialah 6

What is the formula of the compound formed between U and T?

Apakah formula bagi sebatian yang terbentuk antara U dan T?

- A TU
B TU₂
C TU₃
D TU₄

48 Diagram 49 shows the electron arrangement of a compound formed between element T and element Q.

Rajah 49 menunjukkan susunan elektron bagi sebatian yang terbentuk daripada unsur T dan unsur Q.

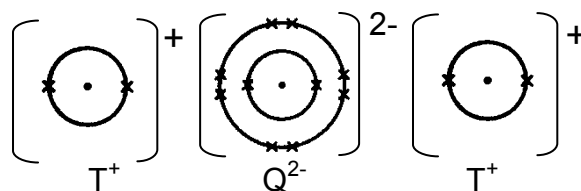

Diagram 49
Rajah 49

What group in the Periodic Table of Elements is element Q located?
Apakah kumpulan bagi unsur Q dalam Jadual Berkala Unsur?

- A 2
B 8
C 16
D 18

- 49 Assuming that a new element called “Sharine” (symbol Sh) was discovered and it is above fluorine in Group 17 of the Periodic Table of Element, which are the CORRECT statements about “Sharine”?

Andaikan satu unsur baru ditemui dan dinamakan “Sharin” (simbol Sh) dan terletak di atas Florin dan Kumpulan 17 dalam Jadual Berkala Unsur, yang manakah BENAR tentang pernyataan “Sharin”?

- I It is a non-metal.
la adalah bukan logam.
- II It is the most reactive element in Group 17.
la adalah unsur paling reaktif dalam Kumpulan 17.
- III It is the most electronegative element in the Group 17.
la adalah unsur yang paling elektronegatif dalam Kumpulan 17.
- IV It is the most probably in gaseous form at room conditions.
la adalah berbentuk gas pada suhu bilik.
- A I and II only
- B II and III only
- C I, II and III only
- D I, II, III and IV

END OF QUESTION PAPER

NAMA :

TINGKATAN :4541/2

PEPERIKSAAN PERCUBAAN
SIJIL PELAJARAN MALAYSIA 2009

CHEMISTRY
Kertas 2
Mei 2009
2 ½ jam

Dua jam tiga puluh minit

**JANGAN BUKA KERTAS SOALAN INI SEHINGGA
DIBERITAHU**

1. Tulis **nama** dan **tingkatan** anda pada ruangan yang disediakan di atas.
2. Kertas soalan ini adalah dalam **dwibahasa**.
3. Soalan dalam Bahasa Inggeris mendahului soalan yang sepadan dalam Bahasa Melayu.
4. Calon dibenarkan menjawab keseluruhan atau sebahagian soalan sama ada dalam **Bahasa Inggeris** atau **Bahasa Melayu**.
5. Calon dikehendaki membaca maklumat di halaman belakang kertas soalan ini

<i>Untuk Kegunaan Pemeriksa</i>		
Bahagian	Soalan	Markah diperoleh
A	1	
	2	
	3	
	4	
	5	
	6	
B	7	
	8	
C	9	
	10	
Jumlah		

Kertas soalan ini mengandungi **20** halaman bercetak.

@PKPSM Pahang

INFORMATION FOR CANDIDATES
MAKLUMAT UNTUK CALON

1. This question paper consists of three sections: **Section A**, **Section B** and **Section C**.
*Kertas soalan ini mengandungi tiga bahagian: **Bahagian A**, **Bahagian B** dan **Bahagian C**.*
2. Answer **all** questions in Section A. Write your answers for **Section A** in the spaces provided in the question paper.
*Jawab **semua** soalan dalam **Bahagian A**. Tuliskan jawapan bagi **Bahagian A** dalam ruang yang disediakan dalam kertas soalan*
3. Answer **one** question from **Section B** and **one** question from **Section C**. Write your answers for **Section B** and **Section C** on the "answer sheet" provided by the invigilators. Answer questions in **Section B** and **Section C** in detail. You may use equations, diagrams, tables, graphs and other suitable methods to explain your answer.
*Jawab **satu** soalan daripada **Bahagian B** dan **satu** soalan daripada **Bahagian C**. Tuliskan jawapan bagi **Bahagian B** dan **Bahagian C** pada kertas tulis yang dibekalkan oleh pengawas peperiksaan. Jawab **Bahagian B** dan **Bahagian C** dengan terperinci. Anda boleh menggunakan persamaan, gambar rajah, jadual, graf dan cara lain yang sesuai untuk menjelaskan jawapan anda.*
4. The diagrams in the questions are not drawn to scale unless stated.
Rajah yang mengiringi soalan tidak dilukiskan mengikut skala kecuali dinyatakan
5. Marks allocated for each question or sub-part of the question are shown in brackets.
Markah yang diperuntukkan bagi setiap soalan atau ceraian soalan ditunjukkan dalam kurungan.
6. Show your working. It may help you to get marks.
Tunjukkan kerja mengira. Ini membantu anda mendapatkan markah.
7. If you wish to change your answer, neatly cross out the answer that you have done. Then write down the new answer.
Sekiranya anda hendak membatalkan sesuatu jawapan, buat garisan di atas jawapan itu.
8. You may use a non-programmable scientific calculator.
Anda dibenarkan menggunakan kalkulator saintifik yang tidak boleh diprogramkan.
9. You are advised to spend 90 minutes to answer questions in **Section A**, 30 minutes for **Section B** and 30 minutes for **Section C**.
*Anda dicadangkan mengambil masa 90 minit untuk menjawab soalan dalam **Bahagian A**, 30 minit untuk **Bahagian B** dan 30 minit untuk **Bahagian C**.*
10. Tie together your answer sheets at the end of the examination.
Ikut semua kertas jawapan anda di akhir peperiksaan.

Section A

[60 marks]

Answer **all** questions in this section.
 Jawab **semua** soalan dalam bahagian ini.

- 1 Diagram 1 shows the set - up of apparatus to determine the melting point of substance X by heating solid X until it melts. Then the temperature of substance X is recorded every half minutes when it is left to cool at room temperature.

Rajah 1 menunjukkan susunan radas untuk menentukan takat lebur bagi asetamida dengan memanaskan pepejal asetamida sehingga lebur. Kemudian suhu asetamida direkodkan setiap setengah minit apabila dibiarkan menyejuk pada suhu bilik

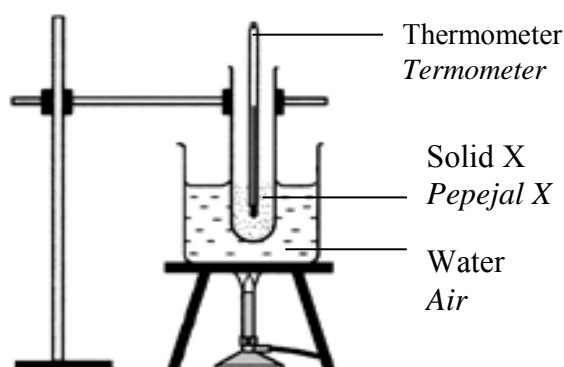

- (a) What is the purpose of using water bath in the experiment?
 Apakah tujuan menggunakan kukus air dalam eksperimen ini?

.....
 [1 mark]

- (b) Name one substance which its melting point can be determined by using water bath.

Namakan satu bahan yang takat leburnya boleh ditentukan menggunakan kukus air

.....
 [1 mark]

- (c) Sodium nitrate has a melting point of 310°C . Can the melting point of sodium nitrate be determined by using water bath as shown in the diagram?

Explain your answer.

*Natrium nitrat mempunyai takat lebur 310°C . Bolehkah takat lebur natrium nitrat di tentukan menggunakan kukus air seperti dalam rajah di atas?
Terangkan jawapan anda.*

.....
.....

[2 marks]

- (d) Why do we need to stir the molten substance X when it is left to cool to room temperature?

Mengapakah kita perlu mengacau leburan asetamida semasa dibiarkan sejuk ke suhu bilik?

..... [1 mark]

- (e) The graph of temperature against time for the cooling of molten substance X is shown below.

Graf suhu melawan masa bagi penyejukan leburan bahan X ditunjukkan di bawah.

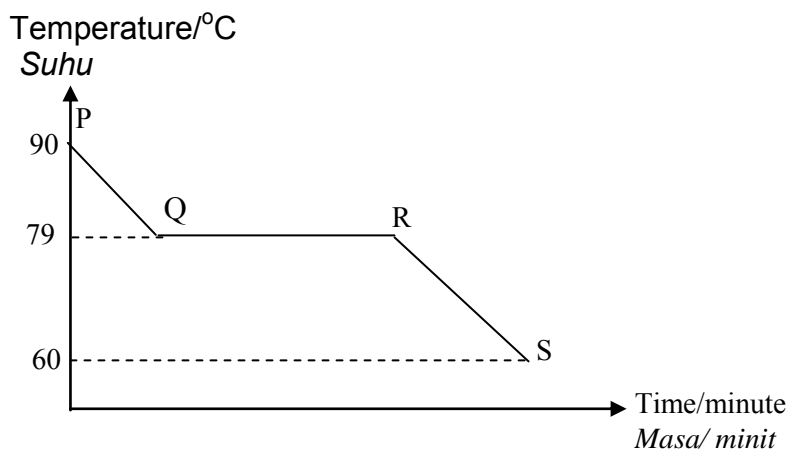

- (i) State the melting point of substance X?
Nyatakan takat lebur bahan X?

..... [1 mark]

- (ii) Explain why there is no change in temperature from Q to R.
Terangkan mengapa suhu tidak berubah dari Q ke R..

.....
..... [2 marks]

- (f) What is the state the of matter for substance X at RS?
Apakah keadaan jirim bagi bahan X pada RS?

.....
[1 mark]

- 2 Diagram 2 shows the symbols of atom for element U, V, W and X.
Rajah 2 menunjukkan simbol- simbol atom bagi unsur U, V, W dan X.



DIAGRAM 2
RAJAH 2

- (a) Write the electron arrangement of atom W.
Tuliskan susunan elektron bagi atom W.

.....
[1 mark]

- (b) (i) Element U, V, W and X are placed in the same period in the Periodic Table.
State the period.
Unsur U, V, W dan X berada dalam kala yang sama dalam Jadual Berkala.
Nyatakan kala itu.

.....
[1 mark]

- (ii) Compare the atomic size of element V and X.
Bandingkan saiz atom unsur V dan X.

.....
[1 mark]

- (iii) Explain your answer in (b) (ii)
Terangkan jawapan anda dalam (b) (ii).

.....
[2 marks]

- (c) Element V can react with element W to form a compound.
Unsur V boleh bertindak balas dengan unsur W membentuk satu sebatian

- (i) Write the chemical formula for the compound.
Tuliskan formula kimia bagi sebatian itu.

.....
[1 mark]

- (ii) State **one** physical property for the compound formed.
Nyatakan satu sifat fizikal bagi sebatian yang terbentuk.

.....
 [1 mark]

- (d) When element U react with element W, a compound is produced.
Apabila unsur U bertindak balas dengan unsur W, satu sebatian terhasil.

- (i) State the type of the compound produced.
Nyatakan jenis sebatian yang terhasil.

.....
 [1 mark]

- (ii) Draw the electron arrangement for the compound in (d) (i).
Lukiskan susunan elektron bagi sebatian dalam (d) (i).

[2 marks]

- 3 Diagram 3 shows the set- up of apparatus to investigate the reaction between potassium iodide solution and chlorine water through the transfer of electrons at a distance..

Rajah 3 menunjukkan susunan radas untuk menyiasat tindak balas di antara larutan kalium iodide dan air klorin melalui pemindahan elektron pada satu jarak.

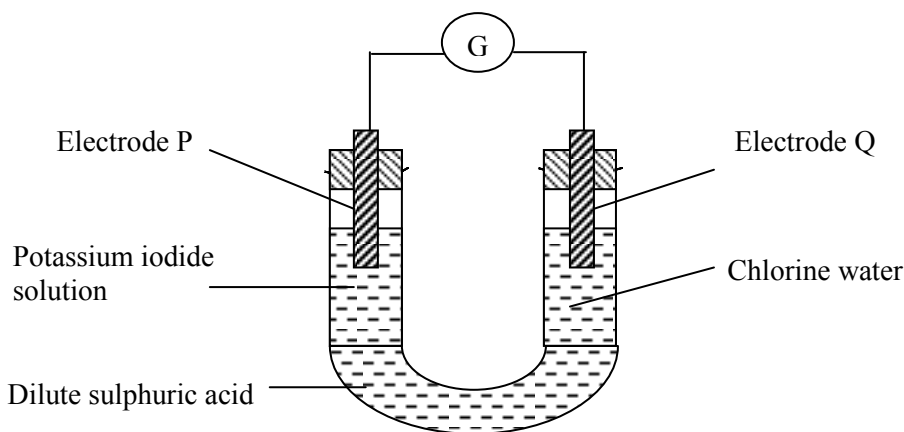

DIAGRAM 3
 RAJAH 3

- (a) What is the function of dilute sulphuric acid?
Apakah fungsi asid sulfurik cair?

.....
 [1 mark]

- (b) On the diagram 3, draw the direction of the flow of electrons.
Pada rajah 3, lukiskan arah pengaliran elektron.

[1 mark]

- (c) (i) What is the colour change in the solution around electrode P?
Apakah perubahan warna dalam larutan di sekitar elektrod?

.....
 [1 mark]

- (ii) Describe a chemical test to determine the product formed in the solution at electrode P.
Huraikan satu ujian kimia untuk menentukan hasil yang terbentuk dalam larutan di elektrod P.

.....

 [2 marks]

- (d) State the name of the substance that is oxidised in the experiment?
 Give reason.
*Nyatakan nama bahan yang dioksidakan dalam eksperimen itu?
 Berikan sebab.*

.....

 [2 marks]

- (e) Write a half equation for the reaction that occurs at electrode Q.
Tuliskan setengah persamaan bagi tindak balas yang berlaku di elektrod Q.

.....
 [1 mark]

- (f) Suggest another reagent that can replace chlorine water.
Cadangkan satu reagen lain yang boleh menggantikan air klorin.

.....
 [1 mark]

- (g) What is the change in oxidation number of chlorine in the reaction?
Apakah perubahan nombor pengoksidaan bagi klorin dalam tindak balas?

.....
 [1 mark]

- 4 Diagram 4.1 shows the method of preparing a soluble salt.
Rajah 4.1 menunjukkan kaedah penyediaan suatu garam larut

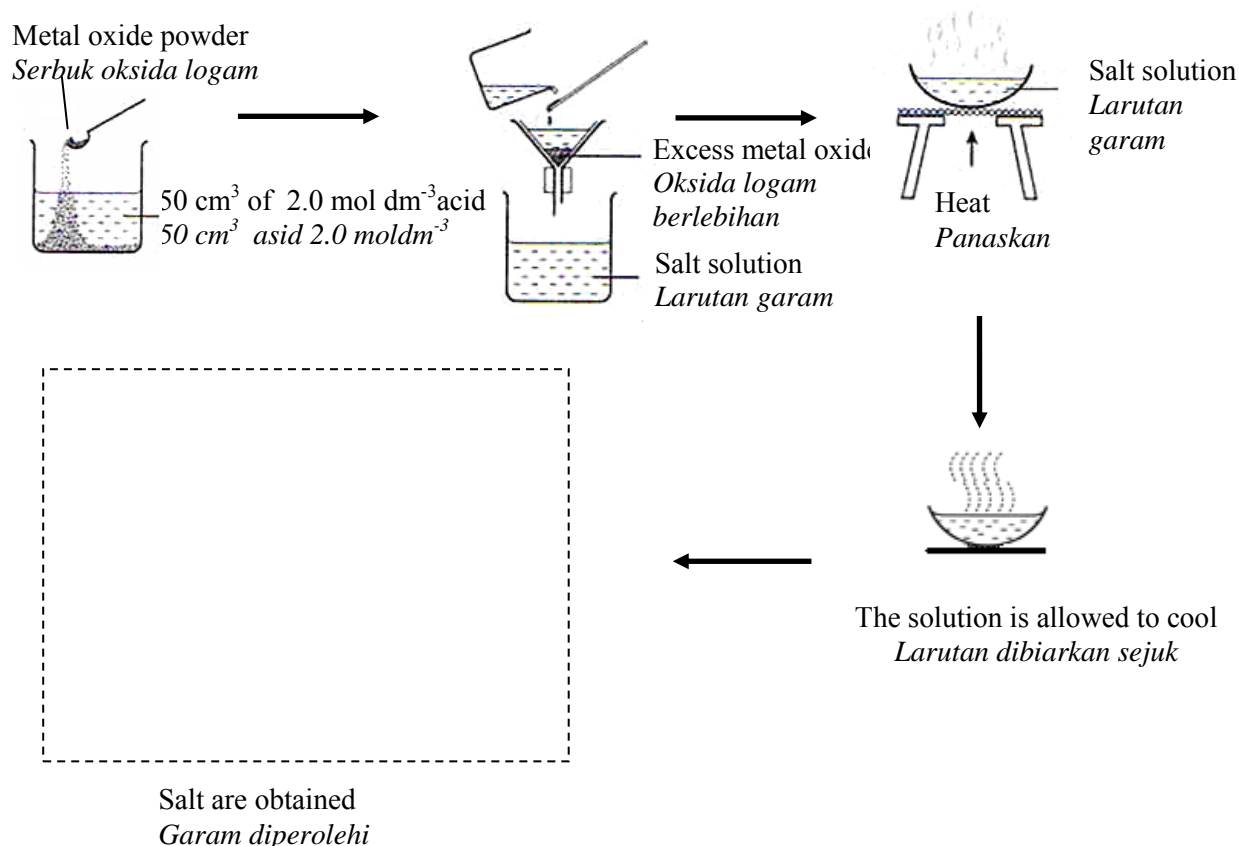

Diagram 4.1
Rajah 4.1

- (a) Based on Diagram 4.1,
Berdasarkan Rajah 4.1,

(i) State two substances that can be used to prepare magnesium chloride.
Nyatakan dua bahan yang boleh digunakan untuk menyediakan magnesium klorida.

.....
[2 marks]

(ii) Complete Diagram 4.1 by drawing the set up of apparatus used to separate the salt crystals and the solution.
Lengkapkan Rajah 4.1 dengan melukis susunan radas yang digunakan untuk memisahkan hablur garam dan larutan.

.....
[2 marks]

- (b) Diagram 4.2 shows another method of preparing salt by mixing solution X and solution Y.

Rajah 4.2 menunjukkan kaedah lain bagi penyediaan garam melalui campuran larutan X dan larutan Y.

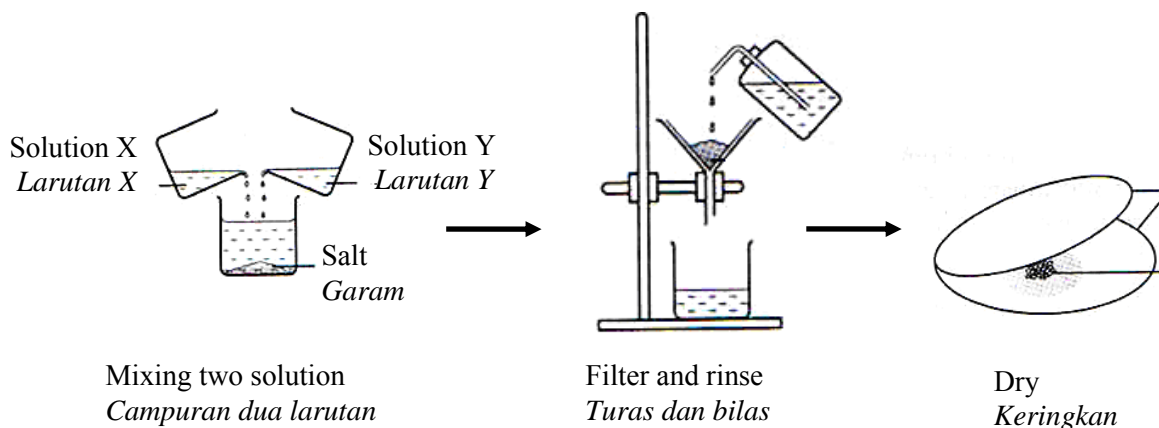

Diagram 4.2
Rajah 4.2

- (i) Name the type of reaction for preparing the salt using this method.
Namakan jenis tindak balas penyediaan garam yang menggunakan kaedah ini

.....
[1 mark]

- (ii) The following solutions are used in the reaction:
Larutan berikut digunakan di dalam tindak balas

Solution X : Potassium sulphate solution
Larutan X : Larutan kalium sulfat

Solution Y : Barium nitrate solution
Larutan Y: Larutan barium nitrat

Write the ionic equation for the formation of barium sulphate salt,
Tuliskan persamaan ion untuk pembentukan garam barium sulfat.

.....
[2 marks]

- (c) The following reaction can be used to prepare zinc chloride salt.
Tindak balas berikut boleh digunakan untuk menyediakan garam zink klorida.



Excess zinc carbonate is added to react with 50 cm³ of 2.0 mol dm⁻³ hydrochloric acid to form the salt.

Zink karbonat berlebihan ditambah untuk bertindak balas dengan 50 cm³ asid hidroklorik 2.0 mol dm⁻³ untuk menghasilkan garam

Calculate the mass of the salt formed.

Hitungkan jisim garam yang terbentuk.

[Relative formula mass of the salt formed is 136]

[Jisim formula relatif garam terbentuk ialah 136]

[3 marks]

5 Diagram 5 shows the apparatus set-up to study the neutralisation between a strong acid and a strong alkali.

Rajah 5 menunjukkan susunan radas untuk mengkaji peneutralan antara satu asid kuat dan satu alkali kuat.

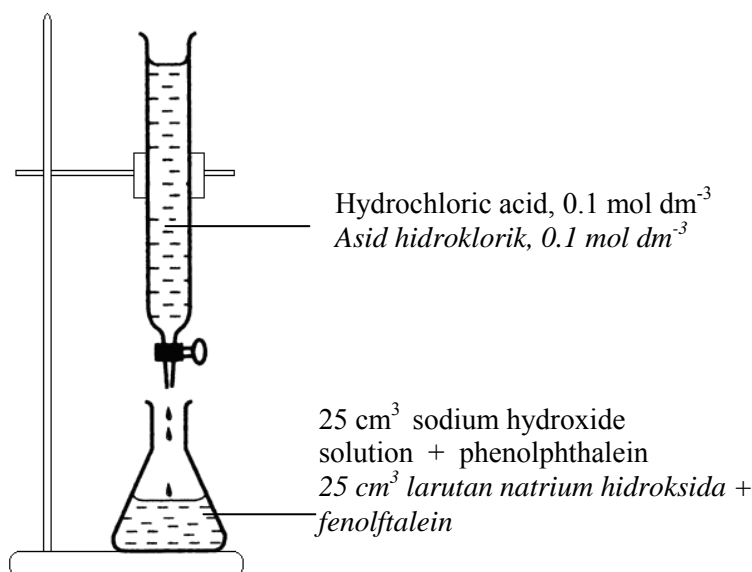

DIAGRAM 1

25.0 cm³ of sodium hydroxide solution is poured into a conical flask. A few drops of phenolphthalein are added into the solution. The solution in the conical flask is titrated with 0.1 mol dm⁻³ hydrochloric acid .

25.0cm³ larutan natrium hidroksida dimasukkan ke dalam sebuah kelalang kon. Beberapa titik fenolftalein ditambah ke dalam larutan itu. Larutan dalam kelalang kon dititratkan dengan 0.1 mol dm⁻³ asid hidroklorik.

(a) Hydrochloric acid is a strong acid. What is meant by a strong acid?

Asid hidroklorik adalah asid kuat. Apakah yang dimaksudkan dengan asid kuat?

.....

[2 marks]

(b) Suggest an apparatus that can be used to measure 25.0 cm³ of sodium hydroxide solution accurately.

Cadangkan satu radas yang dapat digunakan untuk mengukur 25.0 cm³ larutan natrium hidroksida dengan tepat.

.....

[1 mark]

(c) State the colour change of the solution in the conical flask at the end point.

Nyatakan perubahan warna larutan dalam kelalang kon pada takat akhir.

.....

[1 mark]

- (d) (i) Write a chemical equation for the above reaction.
Tulis persamaan kimia bagi tindak balas di atas.

.....
 [1 mark]

- (ii) In this experiment, 20.0 cm³ hydrochloric acid is needed to neutralise 25.0 cm³ of sodium hydroxide solution.

Calculate the molarity of the sodium hydroxide solution.

Dalam eksperimen ini, 20.0 cm³ asid hidroklorik diperlukan untuk meneutralkan 25.0 cm³ larutan natrium hidroksida.

Hitungkan kemolaran larutan natrium hidroksida itu.

[2 marks]

- (e)(i) The experiment is repeated with 0.1 mol dm⁻³ sulphuric acid to replace hydrochloric acid. Predict the volume of sulphuric acid needed to neutralise 25.0 cm³ sodium hydroxide solution.

Eksperimen itu diulang dengan menggunakan 0.1 mol dm⁻³ asid sulfurik bagi menggantikan asid hidroklorik. Ramalkan isipadu asid sulfurik yang diperlukan untuk meneutralkan 25.0 cm³ larutan natrium hidroksida.

.....
 [1 mark]

- (ii) Explain your answer in (e) (i).
Terangkan jawapan anda dalam (e)(i).

.....

 [2 marks]

- 6 A student carried out two experiments to investigate the effects of the factors influencing the rate of reaction. Table 6 shows the results of the experiment. *Seorang pelajar telah menjalankan dua eksperimen untuk mengkaji kesan faktor-faktor yang mempengaruhi kadar tindak balas. Jadual 6 menunjukkan keputusan-keputusan eksperimen tersebut.*

Experiment <i>Eksperimen</i>	Reactants <i>Bahan Tindak Balas</i>	Volume of gas collected in 2 minutes (cm^3) <i>Isipadu gas yang telah dikumpulkan dalam 2 minit (cm^3)</i>
I	2 g of granule calcium carbonate, CaCO_3 and 20 cm^3 of 0.2 mol dm^{-3} hydrochloric acid, HCl <i>2 g ketulan kalsium karbonat, CaCO_3 dan 20 cm^3 asid hidoklorik, HCl 0.2 mol dm^{-3}.</i>	22.00
II	2 g of powdered calcium carbonate, CaCO_3 and 20 cm^3 of hydrochloric acid, HCl 0.2 mol dm^{-3} <i>2 g serbuk kalsium karbonat, CaCO_3 dan 20 cm^3 asi hidoklorik, HCl 0.2 mol dm^{-3}.</i>	37.00

Table 6/ *Jadual 6*

- (a) What is meant by rate of reaction?
Apakah yang dimaksudkan dengan kadar tindak balas?.

.....
.....

[1 mark]

- (b) Calculate the average rate of reaction for Experiment I and Experiment II in cm^3s^{-1}
Hitungkan kadar tindak balas purata untuk Eksperimen I dan Eksperimen II dalam cm^3s

[2 marks]

- (c) Sketch the graphs of the total volume of gas collected against time for Experiment I and II on the same axes.

Pada paksi yang sama, lakarkan graf isipadu gas yang terkumpul melawan masa untuk Eksperimen I dan II.

[2 marks]

- (d) With reference to the Collision Theory, compare and explain why there are differences in the rates of reaction between Experiment I and Experiment II.

Dengan merujuk kepada Teori Perlanggaran, bandingkan dan terangkan mengapa terdapat perbezaan dalam kadar tindak balas antara Eksperimen I dan Eksperimen II.

.....
.....
.....
.....

[4 marks]

- (e) Draw a labelled diagram of the set up of the apparatus for experiment I.

Lukiskan gambar rajah berlabel susunan radas untuk eksperimen I.

[2 marks]

Section B

[20 marks]

Answer any **one** question.[Jawab mana-mana **satu** soalan]

- 7 Diagram 7 shows the flow chart for the industrial manufacture of sulphuric acid and the production of three types of fertilizer.
Rajah 7 menunjukkan carta alir bagi pembuatan asid sulfurik secara industri dan penghasilan tiga jenis baja, baja Y, ammonium nitrat dan urea.

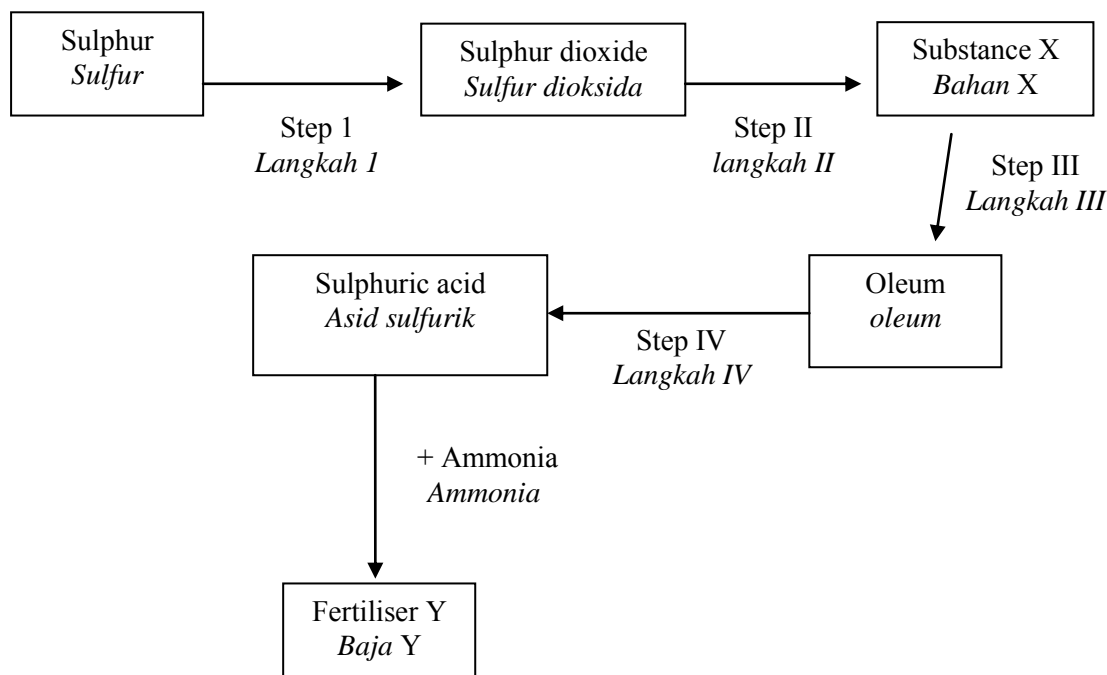

Diagram 7
Rajah 7

- (a) (i) Based on step I to step IV, describe briefly the industrial production of sulphuric acid.
Berdasarkan langkah I hingga langkah IV, huraikan secara ringkas penghasilan asid sulfurik secara industri. [4 marks]
- (ii) The conversion of sulphur dioxide to substance X is very slow and the percentage of conversion is also very low. State three ways to overcome this problem.
Penukaran sulfur dioksida kepada bahan X sangat perlahan dan peratus penukaran juga sangat rendah. Nyatakan tiga cara untuk mengatasi masalah ini. [3 marks]
- (iii) Write a chemical equation for the reaction between sulphuric acid and ammonia to produce fertilizer Y.
Tuliskan persamaan kimia bagi tindak balas antara asid sulfurik dan ammonia untuk menghasilkan baja Y. [2 marks]

- (b) (i) Explain why pure copper is softer than its alloy.
Terangkan mengapa kuprum tulen lebih lembut daripada aloinya. [3 marks]
- (ii) Draw the arrangement of atoms in pure copper and its alloy.
Lukis susunan atom dalam kuprum tulen dan aloinya. [2 marks]
- (iii) State the aim of alloying.
Nyatakan tujuan pengaloiian [3 marks]
- (iv) State the alloy suitable for building bodies of planes and give reasons for your answer.
Nyatakan aloi yang sesuai untuk membina badan pesawat terbang dan berikan sebab bagi jawapan anda. [3 marks]

- 8 (a) Dilute ethanoic acid (vinegar) is electrolysed using carbon electrodes. What is produced at the cathode? Write a half-equation for the reaction.
Elektrolisis asid etanoik cair telah dijalankan menggunakan elektrod – elektrod karbon. Apakah yang terhasil di katod. Tuliskan setengah persamaan bagi tindak balas tersebut. [2 mark]
- (b) Diagram 8 shows two types of cells.
Rajah 8 menunjukkan dua jenis sel.

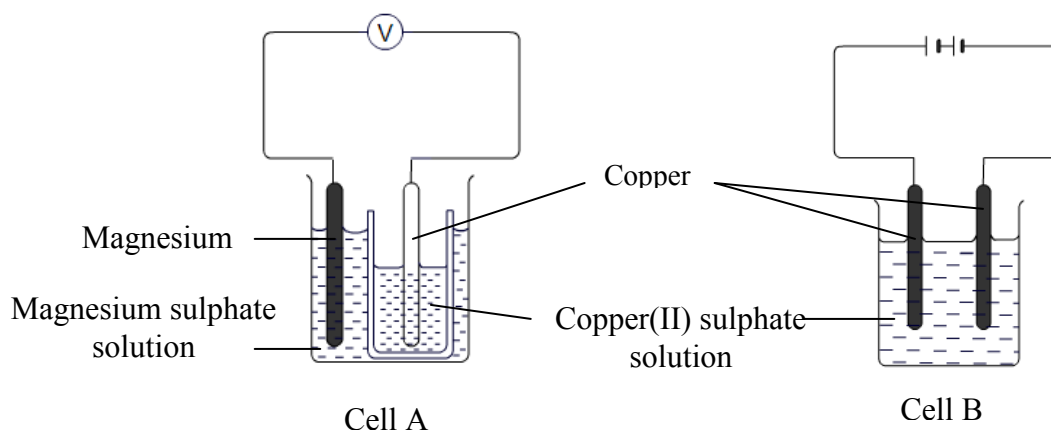

Diagram 8
Rajah 8

Compare and contrast cell A and cell B. Include in your answer the observations and half equations for the reactions at the electrodes in both cells.

Banding dan bezakan sel A dan sel B. Sertakan dalam jawapan anda pemerhatian dan setengah persamaan bagi tindakbalas di elektrod- elektrod kedua-dua sel.

[8 marks]

(c) A student intends to electroplate an iron ring with silver.
Seorang pelajar ingin menyadur cincin besi dengan argentum.

(i) State two purposes of electroplating
Nyatakan dua tujuan penyaduran.

[2 marks]

(ii) Design a laboratory experiment to electroplate the iron ring.
Rancangkan satu eksperimen makmal untuk menyadur cincin besi tersebut.

Your answer should consist of the following

- Procedures of the experiment.
- A labelled diagram showing the set up of apparatus.
- Half equations for the reactions at both electrodes.
- Observations at both electrodes.

Jawapan anda hendaklah termasuk perkara-perkara berikut:

- *Langkah-langkah eksperimen.*
- *Gambar rajah susunan radas berlabel.*
- *Setengah persamaan bagi tindak balas di kedua-dua elektrod.*
- *Pemerhatian di kedua-dua elektrod.*

[8 marks]

Section C
Bahagian C

[20 marks]

Answer any **one** question from this section.
*Jawab mana-mana **satu** soalan daripada bahagian ini.*

- 9 (a) (i) Explain by naming an example each, the meaning of saturated hydrocarbons and unsaturated hydrocarbons.
Dengan menamakan setiap contoh, terangkan maksud hidrokarbon tepu dan hidrokarbon tak tepu

[4marks]

- (ii) Unsaturated hydrocarbon can be converted into saturated hydrocarbon.

- State the process and the condition needed
- Write the chemical equation involved.

Hidrokarbon tak tepu boleh ditukarkan kepada hidrokarbon tepu.

- Nyatakan proses dan keadaan yang diperlukan
- Tuliskan persamaan kimia yang terlibat.

[4marks]

- (b) (i)



Explain briefly how the conversion of homologues series above can be carried out .

Jelaskan dengan ringkas bagaimana pertukaran siri homolog di atas dapat dilakukan.

[4 marks]

- (ii)

Simple carboxylic acid with low molecular mass can dissolve in water to produce acidic solutions

<i>Asid karboksilik yang ringkas dengan jisim molekul yang kecil boleh larut dalam air untuk menghasilkan larutan berasid.</i>
--

By using an example describe the properties of carboxylic acid. Include your answer with chemical equation.

Dengan menggunakan contoh, terangkan sifat-sifat asid karboksilik.

Sertakan persamaan kimia dalam jawapan anda.

[8 marks]

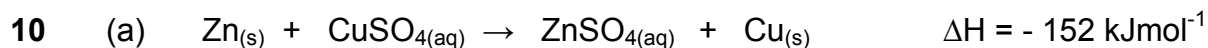

(i) Draw an energy level diagram for the above equation.
Lukiskan gambarajah aras tenaga bagi persamaan di atas.
 [2 marks]

(ii) Explain the differences in energy content of reactants compare to products.
Terangkan perbezaan kandungan tenaga dalam bahan tindak balas berbanding dengan hasil tindak balas.
 [2 marks]

(b) Below is the thermochemical equations of neutralization reaction.
Berikut ialah persamaan termokimia bagi tindak balas peneutralan.

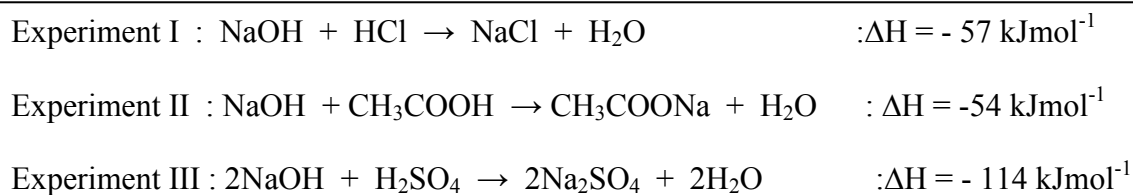

Describe why there are differences of heat of neutralization between;
Terangkan mengapa terdapat perbezaan haba peneutralan antara;

(i) Experiment I and Experiment II
Eksperimen I dan Eksperimen II
 [3 marks]

(ii) Experiment II and Experiment III
Eksperimen II dan Eksperimen III
 [3 marks]

(c)

Heat of combustion is the heat change when one mole of alcohol is completely burnt in oxygen under standard conditions.

Haba pembakaran ialah perubahan haba apabila satu mol alkohol terbakar dengan lengkap dalam oksigen di bawah keadaan piawai.

Describe a laboratory experiment to determine the heat of combustion of one alcohol. In your description, include the following:

[Relative atomic mass : C=12 ; O=16 : H=1]

Huraikan satu eksperimen untuk menentukan haba pembakaran bagi satu alkohol. Dalam huraian anda sertakan perkara berikut;

- diagram showing the set-up of apparatus
gambarajah susunan radas
- procedures of the experiment
prosedur eksperimen
- a table to collect the data
jadual data
- calculating to obtain the heat of combustion
perhitungan haba pembakaran

[10
marks]

**END OF QUESTION PAPER
KERTAS SOALAN TAMAT**

4541/3
Kimia
Paper 3
Sept 2009
1 ½ jam

Nama :

Angka Giliran : Kelas :

PEPERIKSAAN PERCUBAAN SPM 2009

KIMIA

Paper 3

1 hour 30 minutes

**JANGAN BUKA KERTAS SOALAN INI SEHINGGA DIBERITAHU
DO NOT OPEN THIS QUESTION PAPER UNTIL YOU ARE TOLD TO DO SO**

1. *Tuliskan nama, kelas dan angka giliran anda pada ruangan yang disediakan.*
2. *Kertas soalan ini adalah dalam dwibahasa.*
3. *Soalan di bahagian atas adalah dalam Bahasa Inggeris. Soalan di dalam tulisan condong adalah dalam Bahasa Melayu yang sepadan.*
4. *Calon dibenarkan menjawab keseluruhan atau sebahagian soalan sama ada dalam Bahasa Melayu atau Bahasa Inggeris.*
5. *Calon dikehendaki membaca maklumat di halaman 2.*

Kertas soalan ini mengandungi 10 halaman bercetak

<i>Kod Pemeriksa</i>		
Soalan	Markah Penuh	Markah Diperoleh
1	9	
2	24	
3	17	
JUMLAH		

@PKPSM Pahang

INFORMATION FOR CANDIDATES
MAKLUMAT UNTUK CALON

1. Answer **all** questions.
Jawab semua soalan.
2. Write your answer for **Question 1 and Question 2** in the spaces provided in the question paper.
Jawapan kepada Soalan 1 dan Soalan 2 hendaklah ditulis dalam ruangan yang disediakan dalam kertas soalan.
3. Write your answers for **Question 3** on the extra sheet. You may use equations, diagrams, tables, graphs and other suitable methods to explain your answer.
Jawapan kepada Soalan 3 hendaklah ditulis pada helaian tambahan. Anda boleh menggunakan persamaan, gambar rajah, jadual, graf dan cara lain yang sesuai untuk menjelaskan jawapan anda.
4. Show your working, it may help you to get marks.
Tunjukkan kerja mengira, ini membantu anda mendapatkan markah.
5. If you wish to cancel any answer, neatly cross out the answer.
Sekiranya anda hendak membatalkan sesuatu jawapan, buat garisan di atas jawapan itu.
6. The diagrams in the questions provided are not drawn to scale unless stated.
Rajah yang mengiringi tidak dilukiskan mengikut skala kecuali dinyatakan.
7. Marks allocated for each question or part question are shown in brackets.
Markah yang diperuntukkan bagi setiap soalan atau ceraihan soalan ditunjukkan di dalam kurungan.
8. The time suggested to answer Question 1 is 45 minutes and Question 2 is 45 minutes.
Masa yang dicadangkan menjawab Soalan 1 dan 2 ialah 45 minit dan Soalan 2 ialah 45 minit.
9. You may use a non-programmable scientific calculator.
Anda dibenarkan menggunakan kalkulator saintifik yang tidak boleh diprogram.
10. This question paper must be handed in at the end of the examination.
Kertas soalan ini hendaklah diserahkan di akhir peperiksaan.

Marks awarded:

Mark	Description
3	Excellent: The best response provided
2	Satisfactory: An average response provided
1	Weak: An inaccurate response provided
0	No response <u>or</u> wrong response provided



Pemberian markah:

Markah	Penerangan
3	Cemerlang : Respons yang paling baik
2	Memuaskan: Respons yang sederhana
1	Lemah: Respons yang kurang tepat
0	Tiada respons <u>atau</u> respons salah

Answer all questions
 Jawab semua soalan.

For
 Examiner's
 Only
 Kegunaan
 pemeriksa
 sahaja

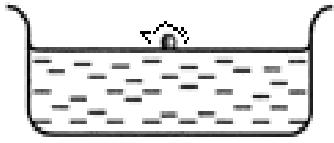
1. A student carried out three experiments to study the reaction of alkali metal with water.
 Seorang pelajar menjalankan tiga eksperimen untuk mengkaji tindak balas di antara logam alkali dengan air.

Set up of experiment apparatus Susunan alat radas eksperimen	Observation of the alkali metal Pemerhatian terhadap logam alkali
	
	
	

(a) Look at the diagram 1. Complete diagram 1 by stating the observations for the reaction of group 1 metals with water based on the movement on the water surface, flame and the sound produce.

Perhatikan gambarajah 1. Lengkapkan gambarajah 1 dengan menyatakan pemerhatian bagi tindak balas di antara logam kumpulan 1 dengan air berdasarkan kepada pergerakannya di atas permukaan air, nyalaan, dan bunyi yang terhasil.

1 (a)

'Hiss'
 'pop'

- (b) After each experiment , a pH meter is dipped into the solution in the basin. The pH value of the solution is 13.

Selepas setiap eksperimen , meter pH dicelupkan ke dalam larutan dalam besen. Nilai pH larutan tersebut ialah 13.

State the inference for the observation.

Nyatakan inferens bagi pemerhatian tersebut

.....

.....

.....

.....

For
Examiner's
Only
*Kegunaan
pemeriksa
sahaja*

1 (b)

- (c) Based on the observations in the experiment above, state the relationship between the position of the elements in Group 1 of the Periodic Table of Elements with the reactivity of the elements towards water.

Berdasarkan pemerhatian-pemerhatian dalam eksperimen di atas, nyatakan hubungan antara kedudukan unsur-unsur Kumpulan 1 dalam Jadual Berkala Unsur dengan kereaktifan unsur-unsur tersebut bertindak balas dengan air.

.....

.....

.....

1 (c)

2. An experiment is carried out to study the relationship between the concentration of hydrogen ions, H^+ and the pH value of hydrochloric acid. Diagram 2 shows the pH value of five solution of hydrochloric acid, a strong acid with different concentration.

Satu eksperimen telah dijalankan untuk mengkaji perhubungan antara kepekatan ion hidrogen, H^+ dengan nilai pH bagi larutan asid hidroklorik. Rajah 2 menunjukkan nilai pH bagi lima larutan asid hidroklorik, suatu asid kuat dengan kepekatan yang berbeza.

For
Examiner's
Only
*Kegunaan
pemeriksa
sahaja*

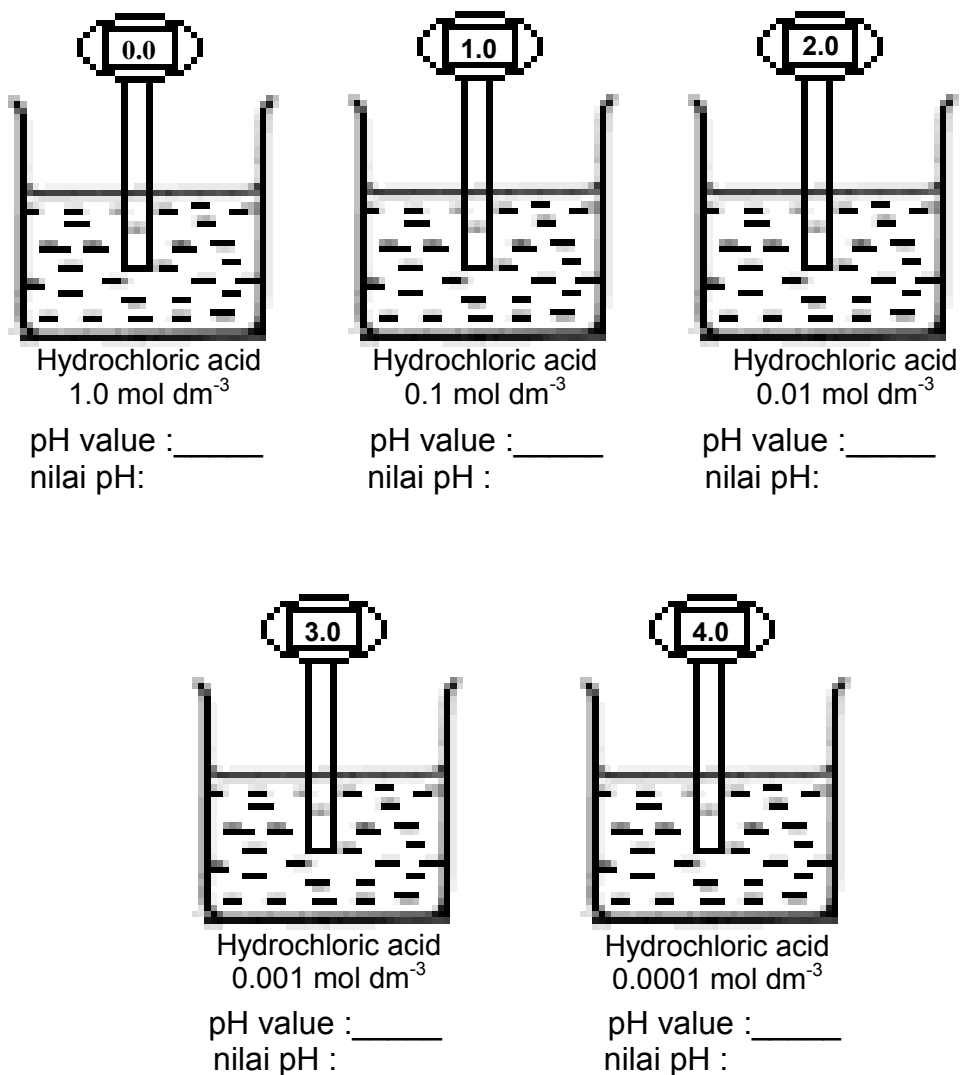

Diagram 2
Rajah 2

- (a) Record the reading of pH value for each of the solution in the spaces provided in Diagram 2.

Catatkan bacaan bagi nilai pH setiap larutan pada ruang yang disediakan dalam Rajah 2

2 (a)

- (b) Construct a table and record the concentration of acid and the pH value for this experiment.
Bina satu jadual dan rekodkan kepekatan asid dan nilai pH dalam eksperimen ini.

.....

For
 Examiner's
 Only
 Kegunaan
 pemeriksa
 sahaja

2 (b)

- (c) Give the operational definition for the strong acid.
Nyatakan definisi secara operasi bagi asid kuat.

.....

2 (c)

- (d) State the variables involved in this experiment
Nyatakan semua pembolehubah yang terlibat dalam eksperimen ini.

Manipulated variable:.....
Pembolehubah yang dimanipulasikan:

Responding variable:.....
Pembolehubah yang bergerakbalas:

Controlled variable:.....
Pembolehubah yang dimalarkan:

2 (d)

- (e) State the hypothesis for this experiment.
Nyatakan hipotesis bagi eksperimen ini.

.....

2 (e)

- (f) Classify the ions in hydrochloric acid solution into anion and cation.
Kelaskan ion-ion dalam larutan asid hidroklorik kepada anion dan kation

For
 Examiner's
 Only
*Kegunaan
 pemeriksa
 sahaja*

2 (f)

- (g) Calculate the number of moles of hydrogen ion in 50 cm³ of 0.01 mol dm⁻³ hydrochloric acid.
Hitungkan bilangan mol ion hidrogen dalam 50cm³ asid hidroklorik 0.01 mol dm⁻³

2 (g)

- (h) Predict the pH value if the experiment is repeated by using 0.01 mol dm⁻³ of ethanoic acid.
Ramalkan bacaan nilai pH jika eksperimen diulang menggunakan larutan asid etanoik 0.01 mol dm⁻³.

.....

.....

.....

2 (h)

Assignment

Carbon dioxide gas can be prepared by the reaction between marble and dilute hydrochloric acid. It is found that the rate of reaction will be different if small chips of marble are replaced with big pieces of marble.

Tugasan

Gas karbon dioksida boleh disediakan dengan tindak balas antara batu marmar dengan asid hidroklorik cair. Didapati kadar tindak balas adalah berbeza jika cebisan kecil batu marmar digantikan dengan ketulan marmar.

Based on the information given, plan a laboratory experiment.

Berdasarkan maklumat di atas , rancangkan satu eksperimen makmal.

The planning of the experiment should contain the following items:

Perancangan eksperimen anda haruslah mempunyai perkara-perkara yang berikut:

- (a) Statements of the problem
Pernyataan masalah
- (b) All the variables involved
Semua pembolehubah
- (c) Statement of the hypothesis
Penyataan hipotesis
- (d) List of the materials and apparatus
Senarai bahan dan alat radas
- (e) Procedure of the experiment
Prosedur eksperimen
- (f) Tabulation of the data
Penjadualan data

[17 marks]

For
Examiner's
Only
*Kegunaan
pemeriksa
sahaja*

3

END OF QUESTION PAPER

SULIT
4541/1
Chemistry
Marking Scheme
September 2009

PEPERIKSAAN PERCUBAAN SPM

CHEMISTRY

Kertas 1

Peraturan pemarkahan ini mengandungi 2 halaman bercetak.

Kertas 1

1	C
2	A
3	D
4	B
5	D
6	D
7	C
8	C
9	B
10	A
11	D
12	C
13	B
14	D
15	A
16	A
17	B
18	A
19	B
20	D

21	C
22	D
23	A
24	A
25	C
26	B
27	C
28	A
29	D
30	B
31	D
32	C
33	C
34	D
35	C
36	C
37	D
38	B
39	A
40	B

41	B
42	C
43	A
44	B
45	B
46	A
47	C
48	D
49	A
50	D

PEPERIKSAAN PERCUBAAN SPM 2009
4541/2 CHEMISTRY
Paper 2

Section A

- | | | | |
|----------|---------|--|----------|
| 1 | (a) | to ensure substance X is heated evenly | 1 |
| | (b) | Naphthalene // benzoic acid // palmitic acid // stearic acid // acetamide | 1 |
| | (c) | No. | 1 |
| | | Sodium nitrate does not melt/the temperature of bath water | 1..... 2 |
| | (d) | is not exceeding 100°C/ boiling point of water is 100°C to avoid supercooling | 1 |
| | | r: even heating | |
| | (e) (i) | 79 °C | 1 |
| | (ii) | Heat loss to surroundings | 1 |
| | | is balance by heat energy liberated as the particle attract one another to form solid | 1..... 2 |
| | (f) | Solid | 1 |
| | | TOTAL | 9 |
| 2 | (a) | 2.7 | 1 |
| | (b) (i) | Period 2 | 1 |
| | (ii) | Atomic size of X is smaller than V // Atomic size of V bigger than X. | 1 |
| | (iii) | The number of proton in atom X is more than V. | 1 |
| | | The attraction by the nucleus on electron in atom X is stronger than V. | 1 |
| | | or | |
| | | The number of proton in atom V is less than X. | 1 |
| | | The attraction by the nucleus on electron in atom V is weaker than X. | 1..... 2 |
| | (c) (i) | VW ₄ | 1 |
| | (ii) | has low melting / boiling point // cannot conduct electricity in any state // soluble in organic solvent | 1 |
| | (d) (i) | Ionic compound | 1 |
| | (ii) | | |

[Number of electron each shells are correct] 1
 [Number of charge and symbol are correct] 1

10

- 3 (a) To allow the transfer of ions. 1
 (b)

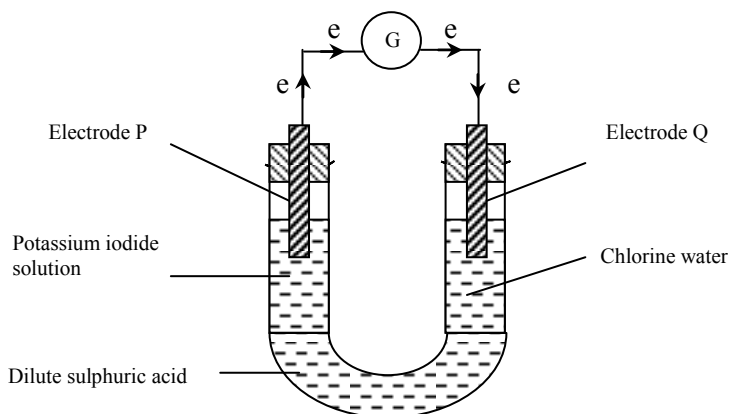

- (c) (i) Colourless change to brown 1
 (ii) Add starch solution. 1
 Dark blue precipitate is formed. 1
- (d) Iodide ion // potassium iodide 1
 Loss electron//increase in oxidation number 1
- (e) $\text{Cl}_2 + 2\text{e} \rightarrow 2\text{Cl}^-$ 1
- (f) Bromine water // acidified KMnO_4 solution // acidified $\text{K}_2\text{Cr}_2\text{O}_7$ solution 1
- (g) 0 to -1 1
- 10**

- 4 (a) (i) magnesium oxide/ magnesium/ magnesium carbonate 1
 Hydrochloric acid 1.....2
 (ii) [Functional diagram] 1
 [Label] 1.....2
- (b) (i) Precipitation reaction // double decomposition 1
 (ii) $\text{Ba}^{2+} + \text{SO}_4^{2-} \rightarrow \text{BaSO}_4$ 1
 [Formula of reactant correct] 1.....2
 [Formula of product correct] 1
- (c) Number of mole hydrochloric acid $= \frac{2 \times 50}{1000} = 0.1 \text{ mol} // 0.1 \text{ mol}$ 1
 Number of mole of zinc chloride $= 0.1/2 = 0.05 \text{ mol}$ 1
 Mass of zinc chloride $= 0.05 \times 136 = 6.8 \text{ g}$ 1.....3
- 10**

- 5 (a) An acid that dissociates/ ionises completely in water to form a high concentration of hydrogen ions 1
1
- (b) pipette 1
- (c) From pink to colourless 1
- (d) (i) $\text{HCl} + \text{NaOH} \rightarrow \text{NaCl} + \text{H}_2\text{O}$ 1
(ii) $\frac{0.1 \times 20}{M_b \times 25} = \frac{1}{1}$ 1
- $25 M_b = 2$
 $M_b = 0.08 \text{ mol dm}^{-3}$ 1
- (e) (i) 10 cm^3 // half the volume of hydrochloric acid 1
(ii) Sulphuric acid is a diprotic acid whereas hydrochloric acid is a monoprotic acid. 1
So, the sulphuric acid used has twice the number of hydrogen ions compared to hydrochloric acid. 1

Total 10

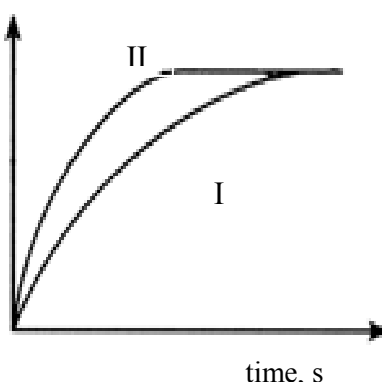
- | No | Marking criteria | Mark |
|------|--|--------|
| 6(a) | The change of amount of reactant / product per unit time. | 1 |
| (b) | Experiment I :
Rate of reaction = $\frac{22}{2 \times 60} = 0.183 \text{ cm}^3 \text{ s}^{-1}$ | 1 |
| | Experiment II :
Rate of reaction = $\frac{37}{2 \times 60} = 0.308 \text{ cm}^3 \text{ s}^{-1}$ | 1 |
| (c) | <p>Volume of $\text{CO}_2, \text{ cm}^3$</p>  <p>time, s</p> <ul style="list-style-type: none"> - Axes are labelled correctly and have correct unit - Correct curves and curves are labelled | 1
1 |
| (d) | - experiment II has a higher rate of reaction compared to experiment I | 1 |

- marble chips in experiment II are smaller in size as compare to experiment I. // marble chips in experiment II has bigger total surface area compare to experiment I 1
- the frequency of collision between CaCO_3 and H^+ ions increases, 1
- the frequency of effective collision increases, 1

(e)

Experiment I

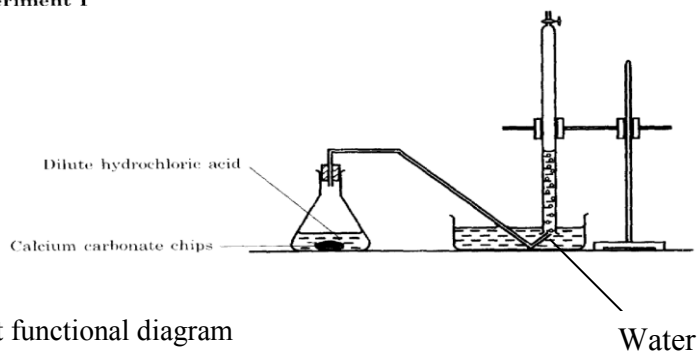

1. correct functional diagram 1
2. labeled 1

TOTAL 11

Section B

Questions		Marking criteria	Marks	
7	(a) (i)	Sulphur is burnt in air to produce sulphur dioxide // Burning of metal sulphides/zinc sulphide / lead sulphide produce sulphur dioxide Sulphur dioxide is oxidised to sulphur trioxide in excess oxygen Sulphur trioxide is dissolved in concentrated sulphuric acid to form oleum. The oleum is diluted with water to produce concentrated sulphuric acid	1 1 1 1	4
	(ii)	Temperature : 450°C Pressure : 1 atmosphere Catalyst : Vanadium(V) oxide	1 1 1	3
	(iii)	$\text{H}_2\text{SO}_4 + 2\text{NH}_3 \rightarrow (\text{NH}_4)_2\text{SO}_4$ Formula for reactants and product correct Balanced	1 1	3
	(b)(i)	1. pure metal atoms have similar size and shape. 2. Easily to slides	1 1	2
	(b)(ii)	1. Draw for pure copper 2. Draw for its alloy and labels for copper and zinc	1 1	2
	(b)(iii)	1. increase the strength and hardness of metal 2. Prevent the corrosion of metal 3. Improve the appearance	1 1 1	2

(b)(iv)	1. Duralamin 2. its stronger/harder 3. Can withstand compression	1 1 1	2
TOTAL			20

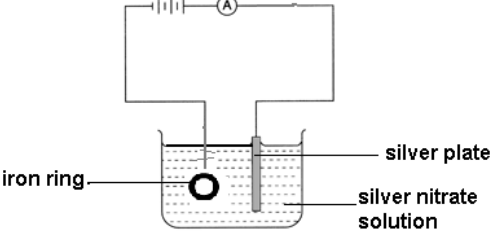
Question s		Marking criteria		Marks																										
8	(a)	1. Hydrogen(gas) 2. $2\text{H}^+ + 2\text{e} \rightarrow \text{H}_2$		1 1	2																									
	(b)	<table border="1" style="width: 100%; border-collapse: collapse;"> <thead> <tr> <th style="width: 25%;">Properties</th> <th style="width: 35%;">Cell A</th> <th style="width: 35%;">Cell B</th> </tr> </thead> <tbody> <tr> <td>1. Type of cell</td> <td>Voltaic cell</td> <td>Electrolytic cell</td> </tr> <tr> <td>2. Energy change</td> <td>Chemical \rightarrow electrical</td> <td>Electrical \rightarrow chemical</td> </tr> <tr> <td>3. Electrodes</td> <td>Positive terminal: Copper Negative terminal: Magnesium</td> <td>Anode: Copper Cathode: Copper</td> </tr> <tr> <td>4. Ions in electrolyte</td> <td>Cu^{2+}, SO_4^{2-}, H^+ and OH^- ions</td> <td>Cu^{2+}, SO_4^{2-}, H^+ and OH^- ions</td> </tr> <tr> <td rowspan="2">5. Half equation</td> <td>Positive terminal: $\text{Cu}^{2+} + 2\text{e} \rightarrow \text{Cu}$</td> <td>Anode: $\text{Cu} \rightarrow \text{Cu}^{2+} + 2\text{e}$</td> </tr> <tr> <td>Negative terminal $\text{Mg} \rightarrow \text{Mg}^{2+} + 2\text{e}$</td> <td>Cathode: $\text{Cu}^{2+} + 2\text{e} \rightarrow \text{Cu}$</td> </tr> <tr> <td rowspan="2">6. Observation</td> <td>Positive terminal: Copper plate becomes thicker</td> <td>Anode: Copper dissolves//become thinner</td> </tr> <tr> <td>Magnesium becomes thinner/dissolve</td> <td>Cathode: Copper becomes thicker</td> </tr> </tbody> </table>		Properties	Cell A	Cell B	1. Type of cell	Voltaic cell	Electrolytic cell	2. Energy change	Chemical \rightarrow electrical	Electrical \rightarrow chemical	3. Electrodes	Positive terminal: Copper Negative terminal: Magnesium	Anode: Copper Cathode: Copper	4. Ions in electrolyte	Cu^{2+} , SO_4^{2-} , H^+ and OH^- ions	Cu^{2+} , SO_4^{2-} , H^+ and OH^- ions	5. Half equation	Positive terminal: $\text{Cu}^{2+} + 2\text{e} \rightarrow \text{Cu}$	Anode: $\text{Cu} \rightarrow \text{Cu}^{2+} + 2\text{e}$	Negative terminal $\text{Mg} \rightarrow \text{Mg}^{2+} + 2\text{e}$	Cathode: $\text{Cu}^{2+} + 2\text{e} \rightarrow \text{Cu}$	6. Observation	Positive terminal: Copper plate becomes thicker	Anode: Copper dissolves//become thinner	Magnesium becomes thinner/dissolve	Cathode: Copper becomes thicker	1 1 1 1 1 1 1 1 1 1	8
Properties	Cell A	Cell B																												
1. Type of cell	Voltaic cell	Electrolytic cell																												
2. Energy change	Chemical \rightarrow electrical	Electrical \rightarrow chemical																												
3. Electrodes	Positive terminal: Copper Negative terminal: Magnesium	Anode: Copper Cathode: Copper																												
4. Ions in electrolyte	Cu^{2+} , SO_4^{2-} , H^+ and OH^- ions	Cu^{2+} , SO_4^{2-} , H^+ and OH^- ions																												
5. Half equation	Positive terminal: $\text{Cu}^{2+} + 2\text{e} \rightarrow \text{Cu}$	Anode: $\text{Cu} \rightarrow \text{Cu}^{2+} + 2\text{e}$																												
	Negative terminal $\text{Mg} \rightarrow \text{Mg}^{2+} + 2\text{e}$	Cathode: $\text{Cu}^{2+} + 2\text{e} \rightarrow \text{Cu}$																												
6. Observation	Positive terminal: Copper plate becomes thicker	Anode: Copper dissolves//become thinner																												
	Magnesium becomes thinner/dissolve	Cathode: Copper becomes thicker																												
	(c)	(i)	Improve the appearance//to make it more attractive To prevent/ reduce corrosion/ rusting	1 1	2																									
		(ii)	Procedure: 1. Iron ring is then connected to the negative plate on the battery while the silver plate is connected to the positive terminal of the battery//Iron ring is made as cathode while silver plate is made as anode 2. Both plates are immersed into the silver nitrate solution. 3. The circuit is completed  Functional apparatus set-up Label correctly: silver plate, Silver nitrate solution, Iron ring Cathode: $\text{Ag}^+ + \text{e} \rightarrow \text{Ag}$	1 1 1 1 1 1																										

		Observation: Grey /silvery solid is deposited Anode : $\text{Ag} \rightarrow \text{Ag}^+ + \text{e}$ Observation: Anode/silver become thinner//dissolve	1 1 1	max 8/9
TOTAL				20

SECTION C

Question s		Marking criteria	Marks	
9	(a) (i)	Saturated hydrocarbons – hydrocarbons that contain only carbon-carbon single bonds or single covalent bond. Example : hexane	2	4
		Unsaturated hydrocarbons – hydrocarbons that contain at least one carbon-carbon double or triple bond. Example : Propene	2	
	(ii)	By Hydrogenation process. Ethene reacts with hydrogen at 180°C in the presence of nickel or platinum catalyst to form ethane.	1 1	
		$\begin{array}{c} \text{H} & \text{H} \\ & \\ \text{H} - \text{C} = & \text{C} - \text{H} \end{array} + \text{H}_2 \rightarrow \begin{array}{c} \text{H} & \text{H} \\ & \\ \text{H} - \text{C} - & \text{C} - \text{H} \\ & \\ \text{H} & \text{H} \end{array}$ <p>accepted: chemical equation</p>	2	
	(b) (i)	- refluxing ethanol/alcohol with an oxidizing agent such as acidified potassium dichromate(VI) solution or Potassium manganate (VII) solution.	2	4
		- esterification reaction carboxylic acid reacts with alcohol with the presence of concentrated sulphuric acid as a catalyst	2	
	(ii)	a) carboxylic acid reacts with metal to produce hydrogen gas $2\text{CH}_3\text{CH}_2\text{OOH} + \text{Zn} \rightarrow \text{Zn}(\text{CH}_3\text{CH}_2\text{O})_2 + \text{H}_2$ (any example) (any electropositive metal – not Na/K)	2	
		b) carboxylic acid reacts with base to produce salt and water $2\text{CH}_3\text{CH}_2\text{OOH} + \text{ZnO} \rightarrow \text{Zn}(\text{CH}_3\text{CH}_2\text{O})_2 + \text{H}_2\text{O}$ (any example) (any base)	2	
		c) carboxylic acid reacts with carbonate to produce salt, carbon dioxide and water $2\text{CH}_3\text{CH}_2\text{OOH} + \text{ZnCO}_3 \rightarrow \text{Zn}(\text{CH}_3\text{CH}_2\text{O})_2 + \text{H}_2\text{O} + \text{CO}_2$ (any example) (any carbonate)	2	

		d) carboxylic acid reacts with alkali to produce salt and water $\text{CH}_3\text{CH}_2\text{COOH} + \text{NaOH} \rightarrow \text{CH}_3\text{CH}_2\text{COONa} + \text{H}_2\text{O}$ (any carboxylic acid) (any alkali)	2	Max 8
		e) pH 3-4 , sour taste, conduct electricity	2	
		TOTAL		20

Question s	Marking criteria	Marks			
10	(a) (i)	<p>1. Y-axes : energy 2. Two different level of energy</p>		1 1	2
	(ii)	1. reactants have more energy // products have less energy 2. energy is released during the experiment // this is exothermic reaction	1 1	2	
	(b) (i)	1. HCl is strong acid // CH ₃ COOH is weak acid 2. strong acid / HCl ionized completely and weak acid ionized / CH ₃ COOH partially in water 3. when neutralization occurs, some of the heat released are absorbed by ethanoic acid / CH ₃ COOH to break the bonds in the molecules.	1 1 1	3	
	(ii)	1. H ₂ SO ₄ is diprotic acid // HCl is monoprotic acid 2. H ₂ SO ₄ / diprotic acid produced two mole of hydrogen ion / H ⁺ // HCl / monoprotic acid produced one mole of hydrogen ion / H ⁺ when ionized in water 4. diprotic acid produced 2 mole of water and monoprotic acid produced 1 mole of water	1 1 1	3	

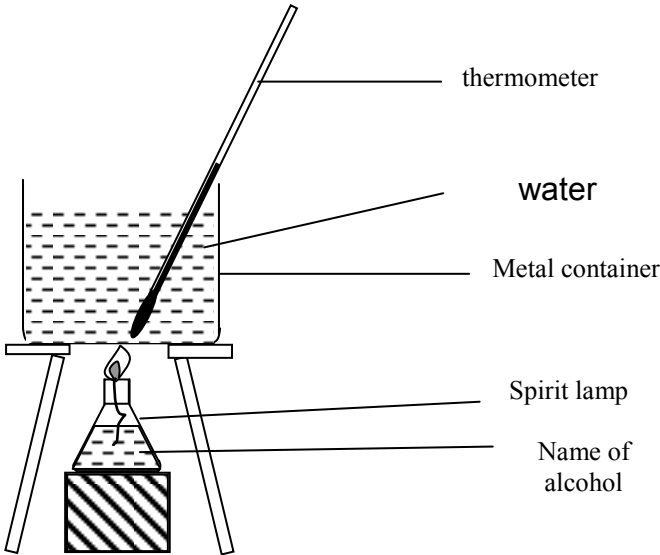
(c)	<p>1.diagram : 2 m 2.procedures : 6 m 3.calculation : 2 m</p> <p>Sample answer :</p>  <p>- functional diagram : 1 m - labeled diagram : 1 m (thermometer, metal container, spirit lamp, alcohol)</p>			2
	<p>Procedures :</p> <ol style="list-style-type: none"> 1. 100 cm³ of water is measured and poured into metal container 2. the initial temperature of water is recorded 3. the #name for one alcohol# is poured into spirit lamp and is weighed 4. the spirit lamp is put under the metal container and is burnt 5. the wick of lamp is lit and water is heated until temperature increases by 30 °C. 6. the spirit lamp is weighed again 			<p>1 1 1 1 1 1</p> <p>6</p>

		<p>Table of data :</p> <table border="1"> <tbody> <tr> <td>Initial temperature of the water ($^{\circ}\text{C}$)</td> <td>Θ_1</td> </tr> <tr> <td>Highest temperature of the water ($^{\circ}\text{C}$)</td> <td>Θ_2</td> </tr> <tr> <td>Mass of spirit lamp before burning (g)</td> <td>m_1</td> </tr> <tr> <td>Mass of spirit lamp after burning (g)</td> <td>m_2</td> </tr> </tbody> </table> <p>Calculation :</p> <p>mole of ethanol = $\frac{m_2 - m_1}{46} = m$</p> <p>heat given out = $mc(\Theta_2 - \Theta_1)$ = x J</p> <p>heat of combustion of ethanol = $\frac{x}{m} \text{ kJmol}^{-1}$ = y kJmol^{-1}</p>	Initial temperature of the water ($^{\circ}\text{C}$)	Θ_1	Highest temperature of the water ($^{\circ}\text{C}$)	Θ_2	Mass of spirit lamp before burning (g)	m_1	Mass of spirit lamp after burning (g)	m_2		
Initial temperature of the water ($^{\circ}\text{C}$)	Θ_1											
Highest temperature of the water ($^{\circ}\text{C}$)	Θ_2											
Mass of spirit lamp before burning (g)	m_1											
Mass of spirit lamp after burning (g)	m_2											
		TOTAL		20								

4541/3
Kimia
Kertas 3
Peraturan
Pemarkahan
2009

**PEPERIKSAAN PERCUBAAN
SIJIL PELAJARAN MALAYSIA 2009**

KIMIA

KERTAS 3

PERATURAN PEMARKAHAN

UNTUK KEGUNAAN PEMERIKSA SAHAJA

AMARAN

Peraturan pemarkahan ini **SULIT** dan **Hak Cipta Jabatan Pelajaran Pahang**. Kegunaannya khusus untuk pemeriksa berkenaan sahaja

Peraturan Pemarkahan ini mengandungi 10 halaman bercetak

**MARKING SCHEME
TRIAL EXAM 2009**

Question Number	Rubric	Score
1 (a)	[able to state three observations for each of the experiment correctly,] Sample answer: 1. lithium moves slowly on the water surface. 2. sodium moves faster and randomly on the surface of the water with a hissing sound and ignites with a yellow flame. 3. potassium moves vigorously and randomly on the water surface and ignites with a lilac flame and produced „pop“ and „hiss“ sound	3
	[able to state two observations correctly]	2
	[able to state one observations correctly]	1
	No response or wrong response	0

Question Number	Rubric	Score
1 (b)	Able to state an inference correctly Sample answer: The solution produced is a strong alkali	3
	Able to state an inference less correctly Sample answer: The solution produced is an alkali	2
	Able to give idea for inference Sample answer: The metals dissolve in water	1
	No response or wrong response	0

Question Number	Rubric	Score
1(c)	Able to state the relationship accurately Sample answer: The lower the position of the metal in group 1 , the higher the reactivity of the metal towards water. // going down the group 1 the reactivity when react with water increases	3
	Able to state the relationship correctly but less accurate Sample answer: Different types of alkali metals, different reactivity of metals// Reactivity of metals depends on different types of alkali metals	2

	Able to state any idea of relationship Sample answer: Reactivity of metal depends on the position of metal// Potassium is the most reactive metal when react with water	1
	No response or wrong response	0

Question Number	Rubric	Score
2(a)	Able to write all the pH value accurately Sample answer: 1.0 mol dm ⁻³ = 0.0 0.1 mol dm ⁻³ = 1.0 0.01 mol dm ⁻³ = 2.0 0.001 mol dm ⁻³ = 3.0 0.0001 mol dm ⁻³ = 4.0	3
	Able to write at least 4 reading of pH value accurately	2
	Able to write at least 3 reading of the pH accurately	1
	No response or wrong response	0

Question Number	Rubric	Score												
2(b)	Able to construct a table and record the data accurate and correctly contains the following information: <ol style="list-style-type: none"> Heading in the table: concentration,pH value transfer all pH value taken correctly, value of different concentration correctly concentration with unit Sample answer : <table border="1" data-bbox="347 1451 1056 1756"> <thead> <tr> <th>Concentration of hydrochloric acid /mol dm⁻³</th> <th>pH value</th> </tr> </thead> <tbody> <tr> <td>1.0</td> <td>0.0</td> </tr> <tr> <td>0.1</td> <td>1.0</td> </tr> <tr> <td>0.01</td> <td>2.0</td> </tr> <tr> <td>0.001</td> <td>3.0</td> </tr> <tr> <td>0.0001</td> <td>4.0</td> </tr> </tbody> </table>	Concentration of hydrochloric acid /mol dm ⁻³	pH value	1.0	0.0	0.1	1.0	0.01	2.0	0.001	3.0	0.0001	4.0	3
Concentration of hydrochloric acid /mol dm ⁻³	pH value													
1.0	0.0													
0.1	1.0													
0.01	2.0													
0.001	3.0													
0.0001	4.0													
	Able to construct a table that contains the following information: <ol style="list-style-type: none"> Heading in the table: concentration,pH value transfer all pH value taken correctly, value 	2												

	of different concentration correctly 3. concentration without unit	
	Able to construct a table that contain at least one heading and 2 readings of concentration and their pH value correctly.	1
	No response or wrong response	0

Question Number	Rubric	Score
2(c)	Able to state the operational definition for strong acid accurately. Sample answer: An acid that has the lower pH value that ionise completely in water to produce high concentration of hydrogen ion.	3
	Able to state the definition for strong acid Sample answer: acid that ionise completely and produce high concentration of hydrogen ion.	2
	Able to state an idea of acid Acid has a sour taste	1
	No response or wrong response	0

Question Number	Rubric	Score
2(d)	Able to state three variables accurately Sample answer: Manipulated variable: concentration of acid Responding variable: pH value Controlled variable: type of acid used/hydrochloric solution, //volume of acid	3
	Able to state two variables accurately	2
	Able to state one variable accurately or any two uncomplete variables	1
	No response or wrong response	0
Question Number	Rubric	Score
2(e)	Able to state the hypothesis correctly Sample answer: The higher/lower the concentration of hydrogen ions, H^+ , the lower/hihger the pH value	3
	Able to state inference less accurate If concentration of acid increase/decrease, the pH value high/low //concentration of hydrogen ion is inversely proportional to the pH value	2
	Able to give idea of hypothesis	1

	concentration of hydrogen ion influence pH value	
	No response or wrong response	0

Question Number	Rubric	Score				
2(f)	<p>Able to classify all the ions in acid into anion and cation correctly</p> <p>Sample answer:</p> <table border="1"> <tr> <td>anion</td> <td>cation</td> </tr> <tr> <td>chloride ion(Cl^-), hydroxide ion(OH^-)</td> <td>hydrogen ion (H^+)</td> </tr> </table> <p>or</p> <p>Anion- chloride ion(Cl^-),hydroxide ion(OH^-) Cation- hydrogen ion (H^+)</p>	anion	cation	chloride ion(Cl^-), hydroxide ion(OH^-)	hydrogen ion (H^+)	3
anion	cation					
chloride ion(Cl^-), hydroxide ion(OH^-)	hydrogen ion (H^+)					
	<p>Able to classify at least one anion and cation correctly</p> <p>Sample answer:</p> <table border="1"> <tr> <td>anion</td> <td>cation</td> </tr> <tr> <td>chloride ion(Cl^-) / hydroxide ion(OH^-)</td> <td>hydrogen ion (H^+)</td> </tr> </table> <p>or</p> <p>Anion- chloride ion(Cl^-) / hydroxide ion(OH^-) Cation- hydrogen ion (H^+)</p>	anion	cation	chloride ion(Cl^-) / hydroxide ion(OH^-)	hydrogen ion (H^+)	2
anion	cation					
chloride ion(Cl^-) / hydroxide ion(OH^-)	hydrogen ion (H^+)					
	<p>Able to classify anion and cation correctly but in opposite group:</p> <p>Sample answer</p> <table border="1"> <tr> <td>cation</td> <td>anion</td> </tr> <tr> <td>chloride ion(Cl^-), hydroxide ion(OH^-)</td> <td>hydrogen ion (H^+)</td> </tr> </table> <p>Or</p> <p>cation- chloride ion(Cl^-) , hydroxide ion(OH^-) anion- hydrogen ion (H^+)</p>	cation	anion	chloride ion(Cl^-), hydroxide ion(OH^-)	hydrogen ion (H^+)	1
cation	anion					
chloride ion(Cl^-), hydroxide ion(OH^-)	hydrogen ion (H^+)					
	No response or wrong response	0				

Question Number	Rubric	Score
2(g)	<p>Able to calculate the number of mole correctly by showing a correct step of calculation and the correct answer with unit</p> <p>Sample answer:</p> <p style="text-align: center;">: $\frac{0.01 \times 50}{1000}$:0.0005 mol</p>	3

	Able to show a correct step of calculation and the correct answer without unit Sample answer: : $\frac{0.01 \times 50}{1000}$: 0.0005	2
	Able to show either one step of calculation or the answer without unit Sample answer: : $\frac{0.01 \times 50}{1000}$ // : 0.005	1
	No response or wrong response	0

Question Number	Rubric	Score
2 (h)	Able to predict pH value of 0.01 mol dm^{-3} ethanoic acid correctly Sample answer: $4 \leq \text{pH value} \leq 5$	3
	Able to predict pH value of 0.01 mol dm^{-3} ethanoic acid less accurately Sample answer: > 5 and ≤ 6.9	2
	Able to state an idea oh pH value Sample answer: Any value between 1 and 14	1
	No response or wrong response	0

Question Number	Rubric	Score
3 (a)	Able to give statement of problem correctly Sample answer: Does the smaller pieces of marble chips increase the rate of reaction?// How does the total surface of reactants affect the rate of reaction?	3
	Able to give statement of problem less correctly Sample answer: Does the size of marble chips increase the rate of reaction?// To study the particle size and the rate of reaction.	2
	Able to give an idea about the statement of problem Sample answer: The size of marble chips influences the rate of reaction?	1

	No response or wrong response	0
--	-------------------------------	---

Question Number	Rubric	Score
3(b)	Able to state all variables correctly Sample answer: Manipulated variable: size of marble chips (calcium carbonate/total surface area of marble chips (calcium carbonate) Responding variable: rate of reaction Controlled variable: concentration and volume of hydrochloric acid, mass of marble chips	3
	Able to state any two of the variables above correctly	2
	Able to state any one of the variables above correctly	1
	No response or wrong response	0

Question Number	Rubric	Score
3(c)	Able to state the relationship correctly between the manipulated variable and the responding variable Sample answer When the total surface area marble chips /reactants increases/decrease the rate of reaction increase/decrease// when the size of marble chips increase the rate of reaction decrease	3
	Able to state the relationship between the manipulated variable and the responding variable Sample answer The rate of reaction increases when the total surface area increase// the rate of reaction increases when the size of particle decreases// the rate of reaction depends on the total surface area/size of reactant/particles	2
	Able to state the idea of hypothesis Sample answer Different size gives different rate of reaction	1
	No response or wrong response	0

Question Number	Rubric	Score
-----------------	--------	-------

3(d)	Able to give list of substance and apparatus correctly and completely Sample answer: Substances: [named]acid [with suitable concentration] Name of calcium carbonate[with suitable mass][2 sizes], water Apparatus: Stopwatch, conical flask, stopper and delivery tube, basin, burette, measuring cylinder, named weighing machine	3
	Able to give list of substances and apparatus correctly but not complete Sample answer Substance: [named] acid without mention the concentration , calcium carbonate without different size, water Apparatus: Stopwatch, conical flask, measuring cylinder	2
	Able to give an idea about the list of substances and apparatus Sample answer: Substance : Any acid, marble chips Apparatus: Stopwatch, any suitable container	1
	No response or wrong response	0

Question Number	Rubric	Score
3 (e)	Able to state all procedures correctly Sample answer: 1. (1-5) g of granulated calcium carbonate chips is weighed and place them in a conical flask 2. 10-50 cm ³ [any acid] (0.1-2.0)mol dm ⁻³ is pour into the conical flask 3. stopper the flask with a stopper that carries a delivery tube into a basin of water. 4. start the stop watch 5. collect the gas using a inverted burette 6. read and record the burette reading after fixed interval of time 7. experiment is stopped when the burette readings remains unchanged 8. Repeat step 1 to 7 by substituting granulated calcium carbonate with powder.	3
	Able to state all procedures but less accurate Sample answer: Contains step 1,2,4,6 and 7	2
	Able to state an idea about how to carry out the	1

	experiment Sample answer : Contains step 1,2 and 3	
	No response or wrong response	0

Question Number	Rubric	Score																																				
3 (f)	<p>Able to show the suitable and complete tabulation of data with th following aspects</p> <ol style="list-style-type: none"> 2 split table of 3 rows and 5 column correct titles of time,burette reading and volume of gas collected with unit <p>sample answer: Exp 1 : Calcium carbonate chips</p> <table border="1"> <tr> <td>Time/s</td> <td>0</td> <td>30</td> <td>90</td> <td>120</td> <td>150</td> </tr> <tr> <td>Burette reading/cm³</td> <td></td> <td></td> <td></td> <td></td> <td></td> </tr> <tr> <td>Volume of gas/cm³</td> <td></td> <td></td> <td></td> <td></td> <td></td> </tr> </table> <p>Exp 1 : Calcium carbonate powder</p> <table border="1"> <tr> <td>Time/s</td> <td>0</td> <td>30</td> <td>90</td> <td>120</td> <td>150</td> </tr> <tr> <td>Burette reading/cm³</td> <td></td> <td></td> <td></td> <td></td> <td></td> </tr> <tr> <td>Volume of gas/cm³</td> <td></td> <td></td> <td></td> <td></td> <td></td> </tr> </table>	Time/s	0	30	90	120	150	Burette reading/cm ³						Volume of gas/cm ³						Time/s	0	30	90	120	150	Burette reading/cm ³						Volume of gas/cm ³						2
Time/s	0	30	90	120	150																																	
Burette reading/cm ³																																						
Volume of gas/cm ³																																						
Time/s	0	30	90	120	150																																	
Burette reading/cm ³																																						
Volume of gas/cm ³																																						
	<p>Able to construct a table with at least</p> <ol style="list-style-type: none"> one title incomplete list of elements 	1																																				
	No response or wrong response	0																																				