

SULIT

NAMA : _____

KELAS : _____

**JABATAN PELAJARAN NEGERI SABAH**

**SIJIL PELAJARAN MALAYSIA 2010
EXCEL 2
ADDITIONAL MATHEMATICS
PAPER 1
OGOS 2010**

3472/1

2 Jam

Dua jam

	Question	Full Marks	Marks Obtained
<p>JANGAN BUKA KERTAS SOALAN INI SEHINGGA DIBERITAHU</p> <p>1. <i>Tuliskan angka giliran dan nombor kad pengenalan anda pada ruang yang disediakan.</i></p> <p>2. <i>Calon dikehendaki membaca arahan di halaman 2.</i></p>	1	2	
	2	2	
	3	3	
	4	4	
	5	3	
	6	3	
	7	3	
	8	3	
	9	2	
	10	3	
	11	3	
	12	4	
	13	3	
	14	2	
	15	3	
	16	4	
	17	4	
	18	3	
	19	3	
	20	4	
	21	4	
	22	4	
	23	4	
	24	3	
	25	4	
Total	80		

This paper consists of 18 printed pages.

**[Lihat sebelah
SULIT**

INFORMATION FOR CANDIDATES

1. *This question paper consists of 25 questions.*
2. *Answer **all** questions.*
3. *Give only **one** answer for each question.*
4. *Write your answers clearly in the space provided in the question paper.*
5. *Show your working. It may help you to get marks.*
6. *If you wish to change your answer, cross out the work that you have done. Then write down the new answer.*
7. *The diagrams in the questions provided are not drawn to scale unless stated.*
8. *The marks allocated for each question are shown in brackets.*
9. *A list of formulae is provided on pages 3 to 5.*
10. *A booklet of four-figure mathematical tables is provided.*
11. *You may use a non-programmable scientific calculator.*
12. *This question paper must be handed in at the end of the examination.*

SULIT

3

3472/1

The following formulae may be helpful in answering the questions. The symbols given are the ones commonly used.

ALGEBRA

$$1. \quad x = \frac{-b \pm \sqrt{b^2 - 4ac}}{2a}$$

$$2. \quad a^m \times a^n = a^{m+n}$$

$$3. \quad a^m \div a^n = a^{m-n}$$

$$4. \quad (a^m)^n = a^{mn}$$

$$5. \quad \log_a mn = \log_a m + \log_a n$$

$$6. \quad \log_a \frac{m}{n} = \log_a m - \log_a n$$

$$7. \quad \log_a m^n = n \log_a m$$

$$8. \quad \log_a b = \frac{\log_c b}{\log_c a}$$

$$9. \quad T_n = a + (n-1)d$$

$$10. \quad S_n = \frac{n}{2}[2a + (n-1)d]$$

$$11. \quad T_n = ar^{n-1}$$

$$12. \quad S_n = \frac{a(r^n - 1)}{r - 1} = \frac{a(1 - r^n)}{1 - r}, r \neq 1$$

$$13. \quad S_\infty = \frac{a}{1 - r}, |r| < 1$$

CALCULUS

$$1. \quad y = uv, \quad \frac{dy}{dx} = u \frac{dv}{dx} + v \frac{du}{dx}$$

$$2. \quad y = \frac{u}{v}, \quad \frac{dy}{dx} = \frac{v \frac{du}{dx} - u \frac{dv}{dx}}{v^2}$$

$$3. \quad \frac{dy}{dx} = \frac{dy}{du} \times \frac{du}{dx}$$

4. Area under a curve

$$= \int_a^b y \, dx \text{ or}$$

$$= \int_a^b x \, dy$$

5. Volume generated

$$= \int_a^b \pi y^2 \, dx \text{ or}$$

$$= \int_a^b \pi x^2 \, dy$$

STATISTICS

1.
$$\bar{x} = \frac{\sum x}{N}$$

2.
$$\bar{x} = \frac{\sum fx}{\sum f}$$

3.
$$\sigma = \sqrt{\frac{\sum (x - \bar{x})^2}{N}} = \sqrt{\frac{\sum x^2}{N} - \bar{x}^2}$$

4.
$$\sigma = \sqrt{\frac{\sum f(x - \bar{x})^2}{\sum f}} = \sqrt{\frac{\sum fx^2}{\sum f} - \bar{x}^2}$$

5.
$$m = L + \left(\frac{\frac{1}{2}N - F}{f_m} \right) c$$

6.
$$I = \frac{Q_1}{Q_0} \times 100$$

7.
$$\bar{I} = \frac{\sum W_i I_i}{\sum W_i}$$

8.
$${}^n P_r = \frac{n!}{(n-r)!}$$

9.
$${}^n C_r = \frac{n!}{(n-r)! r!}$$

10.
$$P(A \cup B) = P(A) + P(B) - P(A \cap B)$$

11.
$$P(X=r) = {}^n C_r p^r q^{n-r}, p+q=1$$

12. Mean, $\mu = np$

13.
$$\sigma = \sqrt{npq}$$

14.
$$Z = \frac{X - \mu}{\sigma}$$

GEOMETRY

1. Distance

$$= \sqrt{(x_1 - x_2)^2 + (y_1 - y_2)^2}$$

2. Midpoint

$$(x, y) = \left(\frac{x_1 + x_2}{2}, \frac{y_1 + y_2}{2} \right)$$

3. A point dividing a segment of a line

$$(x, y) = \left(\frac{nx_1 + mx_2}{m+n}, \frac{ny_1 + my_2}{m+n} \right)$$

4. Area of triangle =

$$\frac{1}{2} |(x_1 y_2 + x_2 y_3 + x_3 y_1) - (x_2 y_1 + x_3 y_2 + x_1 y_3)|$$

5.
$$|z| = \sqrt{x^2 + y^2}$$

6.
$$\hat{r} = \frac{x\hat{i} + y\hat{j}}{\sqrt{x^2 + y^2}}$$

SULIT

5

3472/1

TRIGONOMETRY

1. Arc length, $s = r\theta$
2. Area of sector, $A = \frac{1}{2}r^2\theta$
3. $\sin^2 A + \cos^2 A = 1$
4. $\sec^2 A = 1 + \tan^2 A$
5. $\operatorname{cosec}^2 A = 1 + \cot^2 A$
6. $\sin 2A = 2 \sin A \cos A$
7. $\cos 2A = \cos^2 A - \sin^2 A$
 $= 2 \cos^2 A - 1$
 $= 1 - 2 \sin^2 A$
8. $\sin(A \pm B) = \sin A \cos B \pm \cos A \sin B$
9. $\cos(A \pm B) = \cos A \cos B \mp \sin A \sin B$
10. $\tan(A \pm B) = \frac{\tan A \pm \tan B}{1 \mp \tan A \tan B}$
11. $\tan 2A = \frac{2 \tan A}{1 - \tan^2 A}$
12. $\frac{a}{\sin A} = \frac{b}{\sin B} = \frac{c}{\sin C}$
13. $a^2 = b^2 + c^2 - 2bc \cos A$
14. Area of triangle $= \frac{1}{2}ab \sin C$

For
Examiner's
Use

Answer **all** questions.
Jawab **semua** soalan.

- 1 The relation between $P = \{4, 6, 15, 17\}$ and $Q = \{2, 3, 5, 7\}$ is defined by the ordered pairs of $\{(4, 2), (6, 2), (6, 3), (15, 3), (15, 5)\}$.

Hubungan di antara $P = \{4, 6, 15, 17\}$ dan $Q = \{2, 3, 5, 7\}$ ditakrif oleh pasangan bertertib $\{(4, 2), (6, 2), (6, 3), (15, 3), (15, 5)\}$.

State

Nyatakan

- (a) the object of 5,
objek bagi 5,
- (b) the range of the relation.
julat bagi hubungan tersebut.

[2 marks]
[2 markah]

1

2

Answer / Jawapan : (a).....

(b).....

- 2 Given that $f : x \rightarrow x^2$ and $gf : x \rightarrow x^2 + 2$, find the function g . [2 marks]

Diberi bahawa $f : x \rightarrow x^2$ dan $gf : x \rightarrow x^2 + 2$, carikan fungsi g . [2 markah]

2

2

Answer / Jawapan :

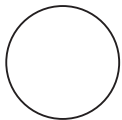

SULIT

7

3472/1

For
Examiner's
Use

3. Given that $f : x \rightarrow 6x + 5$ and $g : x \rightarrow 2x + 3$, find the function fg^{-1} .

Diberi bahawa $f : x \rightarrow 6x + 5$ dan $g : x \rightarrow 2x + 3$, cari fungsi fg^{-1} .

[3 marks]

[3 markah]

3

Answer / Jawapan :

3

4 Given one of the roots of the quadratic equation $x^2 - px - 27 = 0$ is the square of the other root.

Diberi salah satu daripada punca persamaan kuadratik $x^2 - px - 27 = 0$ ialah kuasa dua punca satu lagi.

(a) Find the value of p .

Cari nilai p .

(b) State the roots of the quadratic equation.

Nyatakan punca persamaan kuadratik itu.

[4 marks]

[4 markah]

4

Answer / Jawapan : (a)

4

(b)

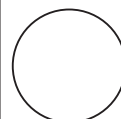

For
Examiner's
Use

- 5** Find the range of values of x for which $5x > 2x^2 - 3$. [3 marks]
Cari julat nilai x bagi $5x > 2x^2 - 3$. [3 markah]

5

	3
--	---

Answer / Jawapan :

- 6** Solve the equation $2^x \square 3^{2x-3} = 12$. [3 marks]
Selesaikan persamaan $2^x \square 3^{2x-3} = 12$. [3 markah]

6

	3
--	---

Answer / Jawapan :

- 7** Solve the equation $\log_4(x+6) - \log_4 x = 1$. [3 marks]
Selesaikan persamaan $\log_4(x+6) - \log_4 x = 1$ [3 markah]

7

	3
--	---

Answer / Jawapan :

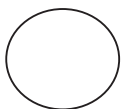

SULIT

9

3472/1

For
Examiner's
Use

- 8 Diagram 8 shows the graph of quadratic function $f(x) = a(x-1)^2 + k$, where a and k are constants. The graph has a minimum point $(1, -8)$.

Rajah 8 menunjukkan graf fungsi kuadratik $f(x) = a(x-1)^2 + k$, dengan keadaan a dan k adalah pemalar. Graf itu mempunyai titik minimum $(1, -8)$.

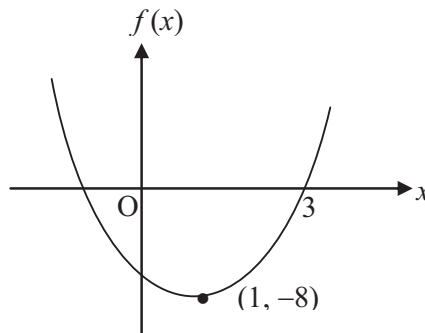

Diagram 8
Rajah 8

State

Nyatakan

- (a) the value of k ,
nilai bagi k ,
- (b) the value of a ,
nilai bagi a ,
- (c) the equation of axis of symmetry.
persamaan bagi paksi simetri.

[3 marks]

[3 markah]

Answer / Jawapan : (a) $k = \dots\dots\dots$

(b) $a = \dots\dots\dots$ **8**

(c) $\dots\dots\dots$ **3**

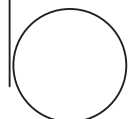

For
Examiner's
Use

9 Find the number of terms in the arithmetic progression, $-18, -13, -8, \dots, 57$.

Cari bilangan sebutan dalam jantang aritmetik, $-18, -13, -8, \dots, 57$.

[2 marks]
[2 markah]

9

2

Answer / Jawapan :

10 The first three terms of a geometric progression are $h + 3, h, h - 2$.

Tiga sebutan pertama suatu jantang geometri ialah $h + 3, h, h - 2$.

Find

Cari

- (a) the value of h ,
nilai h ,
- (b) the common ratio of the progression.
nisbah sepunya jantang itu.

[3 marks]
[3 markah]

10

3

Answer / Jawapan : (a) $h = \dots$

(b)

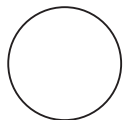

SULIT

11

3472/1

- 11 In a geometric progression, the first term is 4 and the sum of the first two terms is 7. Find the sum to infinity of the progression. [3 marks]

For
Examiner's
Use

Dalam suatu jangjang geometri, sebutan pertama ialah 4 dan hasil tambah dua sebutan pertama ialah 7. Cari hasil tambah hingga sebutan ketakterhinggaan bagi jangjang itu. [3 markah]

11

3

Answer / Jawapan :

- 12 A straight line graph is obtained by plotting $\log_{10} y$ against $\log_{10} x$, as shown in Diagram 12. Given that the equation of graph is $\log_{10} y = 3 \log_{10} x + 4$.

Graf garis lurus diperoleh dengan memplotkan $\log_{10} y$ melawan $\log_{10} x$, seperti yang ditunjukkan di Rajah 12. Diberi bahawa persamaan graf itu ialah $\log_{10} y = 3 \log_{10} x + 4$.

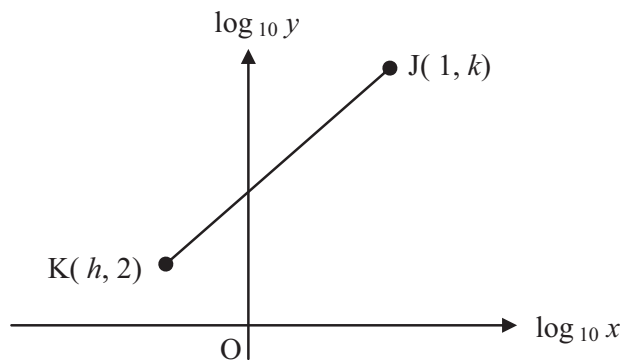

Diagram 12
Rajah 12

Find the value of h and of k .
Cari nilai h dan nilai k .

[4 marks]

[4 markah]

12

Answer / Jawapan : $h =$

4

$k =$



For
Examiner's
Use

- 13 The vertices of a triangle are $A(4, 7)$, $B(h, 3)$ and $C(10, -1)$. Given that triangle ABC is right-angled at B , calculate the possible values of h .

Bucu-bucu sebuah segitiga ialah $A(4, 7)$, $B(h, 3)$ and $C(10, -1)$. Diberi bahawa segitiga ABC bersudut tepat pada B , hitungkan nilai-nilai yang mungkin untuk h .

[3 marks]
[3 markah]

13

3

Answer / Jawapan :

- 14 Diagram 14 shows two vectors, \vec{OP} and \vec{OQ} .
Rajah 14 menunjukkan dua vektor, \vec{OP} dan \vec{OQ} .

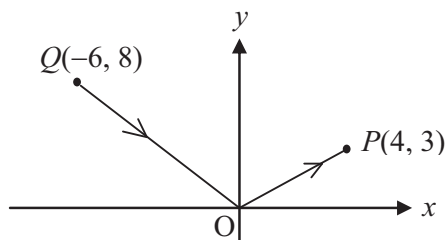

Diagram 14
Rajah 14

Express \vec{PQ} in the form $\begin{pmatrix} x \\ y \end{pmatrix}$. [2 marks]

Ungkapkan \vec{PQ} dalam bentuk $\begin{pmatrix} x \\ y \end{pmatrix}$. [2 markah]

14

2

Answer / Jawapan :

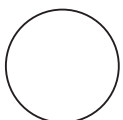

SULIT

13

3472/1

15 Given that $\vec{AB} = \begin{pmatrix} m \\ 3 \end{pmatrix}$ and $\vec{AC} = \begin{pmatrix} -3 \\ n \end{pmatrix}$, find the value of m and of n if $\vec{BC} = \begin{pmatrix} 6 \\ -5 \end{pmatrix}$.

Diberi $\vec{AB} = \begin{pmatrix} m \\ 3 \end{pmatrix}$ dan $\vec{AC} = \begin{pmatrix} -3 \\ n \end{pmatrix}$, cari nilai m dan nilai n jika $\vec{BC} = \begin{pmatrix} 6 \\ -5 \end{pmatrix}$.

[3 marks]

[3 markah]

For
Examiner's
Use

Answer / Jawapan : $m = \dots\dots\dots$

$n = \dots\dots\dots$

15

3

16 Diagram 16 shows a triangle ABC .

Rajah 16 menunjukkan sebuah segitiga ABC

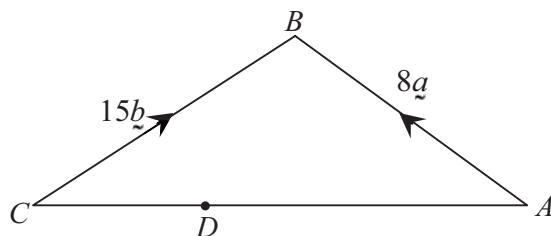

Diagram 16

Rajah 16

The point D lies on AC such that $AD : DC = 2 : 1$.

Titik D terletak pada AC dengan keadaan $AD : DC = 2 : 1$.

Express in terms of \underline{a} and \underline{b}

Ungkapkan dalam sebutan \underline{a} dan \underline{b}

(a) \vec{AC} ,

(b) \vec{BD} .

[4 marks]

[4 markah]

Answer / Jawapan : (a).....

(b).....

16

4



For
Examiner's
Use

17 Solve the equation $3 \cos^2 x - 10 \sin x + 5 = 0$ for $0^\circ \leq x \leq 360^\circ$.

Selesaikan persamaan $3 \cos^2 x - 10 \sin x + 5 = 0$ untuk $0^\circ \leq x \leq 360^\circ$.

[4 marks]

[4 markah]

17

	4
--	---

Answer / Jawaban :

18 It is given that $y = \frac{1}{3}u^5$, where $u = 6x + 1$. Find $\frac{dy}{dx}$ in terms of x .

Diberi bahawa $y = \frac{1}{3}u^5$, dengan keadaan $u = 6x + 1$. Cari $\frac{dy}{dx}$ dalam sebutan x .

[3 marks]

[3 markah]

18

	3
--	---

Answer / Jawaban :

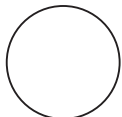

For
Examiner's
Use

SULIT

15

3472/1

19

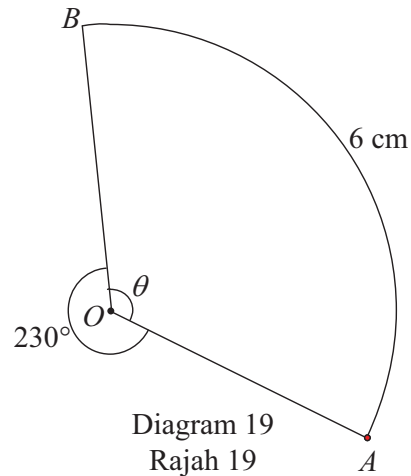

Diagram 19 shows the sector OAB with centre O . The reflex angle of AOB is 230° and the length of the arc AB is 6 cm. Using $\pi = 3.142$, find

Rajah 19 menunjukkan sektor OAB dengan pusat O . Sudut reflex AOB ialah 230° dan panjang lengkok AB ialah 6 cm. Dengan menggunakan $\pi = 3.142$, cari

- (a) the value of θ , in radians,
nilai bagi θ , dalam radian,
- (b) the area, in cm^2 , of sector OAB .
luas, dalam cm^2 , bagi sektor OAB .

[3 marks]
[3 markah]

Answer / Jawapan : (a) $\theta = \dots\dots\dots$

(b) $\dots\dots\dots$

19

	3
--	---

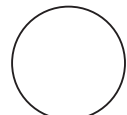

For
Examiner's
Use

- 20** The volume of water, $V \text{ m}^3$, in a tank is given by $V = \frac{3h}{2}(2 + h)^2$, where h is the height of the water, in m, in the tank. Water leaked from the tank at the rate of $12 \text{ m}^3 \text{ s}^{-1}$. Find the rate of change of the height of the water in m s^{-1} , at the instant when its height is 2 m.

[4 marks]

Isipadu air, $V \text{ m}^3$, dalam sebuah tangki diberi oleh $V = \frac{3h}{2}(2 + h)^2$, dengan keadaan h ialah tinggi air, dalam m, dalam bekas itu. Air bocor dari tangki itu dengan kadar $12 \text{ m}^3 \text{ s}^{-1}$. Cari kadar perubahan tinggi air dalam m s^{-1} , pada ketika tingginya ialah 2 m.

[4 markah]

20

	4
--	---

Answer / Jawapan :

- 21** Given that $\int_0^4 g(x) dx = 2$, find
 Diberi bahawa $\int_0^4 g(x) dx = 2$, cari
- (a) $\int_4^0 2g(x) dx$,
- (b) $\int_0^4 [x - g(x)]dx$.

[4 marks]

[4 markah]

21

	4
--	---

Answer / Jawapan : (a)

(b).....

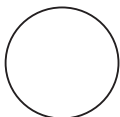

SULIT

17

3472/1

For
Examiner's
Use

22(a) How many five-digit odd numbers can be formed from the digits 5, 6, 7, 8, 9 if no repetition is allowed?

Berapakah bilangan nombor ganjil lima digit yang boleh dibentuk daripada digit 5, 6, 7, 8, 9 tanpa ulangan?

(b) A karate team of 5 members is chosen from 4 girls and 6 boys. Calculate the number of different ways the team can be formed if there is no restriction.

Satu pasukan karate yang terdiri daripada 5 orang ahli dipilih daripada 4 orang perempuan dan 6 orang lelaki. Hitungkan bilangan cara yang berlainan pasukan itu boleh dibentuk jika tiada syarat dikenakan.

[4 marks]
[4 markah]

Answer / Jawapan : (a)

(b).....

22

4

23 A marble is drawn at random from a bag containing 2 white marbles, 3 red marbles and 5 blue marbles.

Sebiji guli dikeluarkan secara rawak dari sebuah beg yang mengandungi 2 biji guli putih, 3 biji guli merah dan 5 biji guli biru.

Find the probability of

Cari kebarangkalian untuk

(a) getting a red or blue marble,
mendapat sebiji guli merah atau biru,

(b) not getting a red marble.
tidak mendapat guli merah.

[4 marks]
[4 markah]

Answer / Jawapan : (a).....

(b).....

23

4

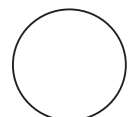

For
Examiner's
Use

- 24 A set of data consists of five numbers. The sum of the numbers is 30 and the sum of the squares of the numbers is 225.

Satu set data mengandungi lima nombor. Hasil tambah bagi nombor-nombor itu ialah 30 dan hasil tambah bagi kuasa dua nombor-nombor itu ialah 225.

- (a) Find the mean for the five numbers.

Cari min bagi lima nombor itu.

- (b) When a number p is added to this set, the mean is unchanged. Hence, find the variance.

Apabila satu nombor p ditambah ke set nombor ini, minnya tidak berubah. Seterusnya, cari varians.

[3 marks]

[3 markah]

24

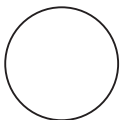
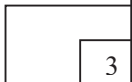

Answer / Jawapan : (a)

(b)

SULIT

19

3472/1

25

For
Examiner's
Use

Diagram 25 shows a standard normal distribution graph.

Rajah 25 menunjukkan satu graf taburan normal piawai.

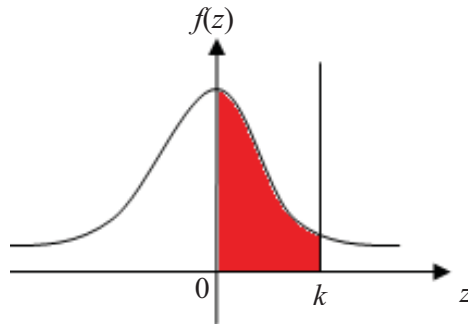

Diagram 25
Rajah 25

Given $P(0 \leq z \leq k)$ is 0.4115.

Diberi $P(0 \leq z \leq k)$ ialah 0.4115.

(a) Find $P(z \geq k)$.

Cari $P(z \geq k)$.

(b) X is a continuous random variable which is normally distributed with a mean of 48 and a variance of 144.

X ialah pembolehubah rawak selanjur bertaburan secara normal dengan min 48 dan varians 144.

Find the value of X when the z -score is k .

Cari nilai X apabila skor- z ialah k

[4 marks]

[4 markah]

Answer / Jawapan : (a)

(b)

25

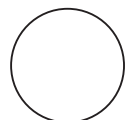

END OF QUESTION PAPER
KERTAS SOALAN TAMAT

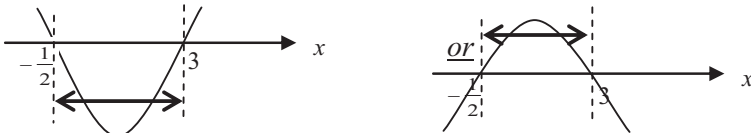
No.	Suggested solution and mark scheme	Sub Marks	Total Marks
1.	(a) 15 (b) {2,3,5}	1 1	2
2.	$g(x) = x + 2$ B1: $g(y) = (\sqrt{y})^2 + 2$ <u>or</u> $g(x^2) = (x^2) + 2$ <u>or</u> $f^{-1}(x) = \sqrt{x}$	2	2
3.	$fg^{-1} = 3x - 4$ B2: $fg^{-1} = 6\left(\frac{x-3}{2}\right) + 5$ B1: $g^{-1} = \frac{x-3}{2}$	3	3
4.	(a) $p = 6$ B2: $\alpha = -3$ B1: $\alpha + \alpha^2 = p$ <u>or</u> $\alpha(\alpha^2) = -27$ (b) -3, 9	3 1	4
5.	$-\frac{1}{2} < x < 3$ <u>or</u> $3 > x > -\frac{1}{2}$ B2:  B1: $(2x+1)(x-3) < 0$ <u>or</u> $(-2x-1)(x-3) > 0$	3	3
6	$x = 2$ B2: $2^x \cdot (3^2)^x = 12 \times 27$ <u>or</u> $2^x \cdot (9)^x = 324$ <u>or</u> $18^x = 324$ <u>or</u> <i>equivalent.</i> B1: $\frac{2^x \cdot 3^{2x}}{3^3} = 12$ <u>or</u> <i>equivalent.</i> <u>OR</u> <i>using logarithms method:</i> $x = 2$ (accept 1.9999) B2: $0.3010x + (2x-3)(0.4771) = 1.079$ <u>or</u> $1.2552x = 2.5103$ B1: $\log_{10} 2^x + \log_{10} 3^{2x-3} = \log_{10} 12$ (accept any base)	3	3

7.	$x = 2$ B2: $\frac{x+6}{x} = 4$ <u>or</u> $x + 6 = 4x$ <u>or equivalent</u> B1: $\log_4 \frac{x+6}{x} = 1$	3	3
8.	(a) $k = -8$ (b) $a = 2$ (c) $x = 1$	1 1 1	3
9.	16 <u>or</u> 16 terms <u>or</u> $n = 16$ B1: $-18 + (n-1)(5) = 57$ <u>or by listing method:</u> $-18, -13, -8, -3, 2, 7, 12, 17, 22, 27, 32, 37, 42, 47, 52, 57.$	2	2
10.	(a) $h = 6$ B1: $\frac{h}{h+3} = \frac{h-2}{h}$ <u>or</u> $h^2 = (h-2)(h+3)$ (b) $r = \frac{2}{3}$	2 1	3
11.	$S_\infty = 16$ B2: $S_\infty = \frac{4}{1-\frac{3}{4}}$ B1: $r = \frac{3}{4}$	3	3
12.	$h = -\frac{2}{3}, k = 7$ (both) B3: $h = -\frac{2}{3}$ <u>or</u> $k = 7$ B2: $2 = 3h + 4$ <u>or</u> $k = 3(1) + 4$ B1: $Y = 3X + 4$	4	3
13.	2, 12 B2: $h^2 - 14h + 24 = 0$ B1: $\frac{3-7}{h-4} \times \frac{3-(-1)}{h-10} = -1$	3	3
14.	$\begin{pmatrix} -10 \\ 8 \end{pmatrix}$ B1: $\vec{PQ} = \vec{PO} + \vec{OQ}$ <u>or</u> $\begin{pmatrix} -4 \\ -3 \end{pmatrix} + \begin{pmatrix} -6 \\ 8 \end{pmatrix}$	2	2
15.	$m = -9, n = -2$ (both) B2: $-m + (-3) = 6$ <u>or</u> $-3 + n = -5$ B1: $\vec{BC} = \vec{BA} + \vec{AC}$ <u>or</u> $\begin{pmatrix} 6 \\ -5 \end{pmatrix} = \begin{pmatrix} -m \\ -3 \end{pmatrix} + \begin{pmatrix} -3 \\ n \end{pmatrix}$ <u>or equivalent</u>	3	3
16.	(a) $8a - 15b$	1	

	<p>(b) $-\frac{8}{3}\underline{a}-10\underline{b}$</p> <p>B2: $\vec{BD} = -8\underline{a} + \frac{2}{3}(8\underline{a}-15\underline{b})$ <u>or</u> $\vec{BD} = -15\underline{b} + \frac{1}{3}(-8\underline{a}+15\underline{b})$</p> <p>B1: $\vec{AD} = \frac{2}{3}(8\underline{a}-15\underline{b})$ <u>or</u> $\vec{BD} = -8\underline{a} + \frac{2}{3}\vec{AC}$</p> <p>OR $\vec{CD} = \frac{1}{3}(-8\underline{a}+15\underline{b})$ <u>or</u> $\vec{BD} = -15\underline{b} + \frac{1}{3}\vec{CA}$</p>	3	
17.	<p>$41.81^\circ, 138.19^\circ$ or $41^\circ 49', 138^\circ 11'$</p> <p>B3: $\sin x = \frac{2}{3}$, $\sin x = -4$ (both)</p> <p>B2: $(3 \sin x - 2)(\sin x + 4) = 0$</p> <p>B1: $3(1 - \sin^2 x) - 10\sin x + 5 = 0$</p>	4	4
18.	<p>$10(6x+1)^4$</p> <p>B2: $\frac{dy}{dx} = \frac{5}{3}u^4 \times 6$</p> <p>B1: $\frac{dy}{du} = \frac{5}{3}u^4$ <u>or</u> $\frac{du}{dx} = 6$</p>	3	3
19.	<p>(a) 2.269</p> <p>(b) 7.933</p> <p>B1: $\frac{1}{2}\left(\frac{6}{2.269}\right)(6)$ <u>or</u> $\frac{1}{2}\left(\frac{6}{2.269}\right)^2(2.269)$ <u>or</u> $r = 2.644$</p>	1 2	3
20.	<p>$\frac{dh}{dt} = -\frac{1}{4}$</p> <p>B3: $-12 = 48 \times \frac{dh}{dt}$</p> <p>B2: $\frac{dV}{dh} = 6 + 12(2) + \frac{9}{2}(2)^2 = 48$</p> <p>B1: $\frac{dV}{dh} = \frac{3}{2}(2+h)^2 + 2\left(\frac{3}{2}h\right)(2+h)$ <u>or</u> $\frac{dV}{dh} = 6 + 12h + \frac{9}{2}h^2$</p>	4	4
21.	<p>(a) -4</p> <p>(b) 6</p> <p>B2: $\left[\frac{x^2}{2}\right]_0^4 - 2$</p> <p>B1: $\int_0^4 x dx - \int_0^4 g(x) dx$</p>	1 3	4
22.	<p>(a) 72</p> <p>B1: $3 \times 4!$</p> <p>(b) 252</p> <p>B1: ${}^{10}C_5$</p>	2 2	4

23	$(a) \frac{4}{5}$ B1 : $\frac{3}{10} + \frac{5}{10}$ $(b) \frac{7}{10}$ B1 : $1 - \frac{3}{10}$ or $\frac{5}{10} + \frac{2}{10}$	2 2	4
24	$(a) 6$ $(b) 7\frac{1}{2}$ B1 : $\frac{225+6^2}{6} - 6^2$	1 2	3
25	$(a) 0.0885$ $(b) 64.2$ B2 : $\frac{x-48}{12} = 1.35$ B1 : $k = 1.35$	1 3	4

SULIT

NAMA : _____

KELAS : _____

**JABATAN PELAJARAN NEGERI SABAH**

SIJIL PELAJARAN MALAYSIA 2010
EXCEL 2
ADDITIONAL MATHEMATICS
Paper 2
SEPTEMBER 2010

3472/2

 $2\frac{1}{2}$ jam

Dua jam tiga puluh minit

JANGAN BUKA KERTAS SOALAN INI SEHINGGA DIBERITAHU

1. *This question paper consists of three sections: **Section A**, **Section B** and **Section C**.*
2. *Answer **all** questions in **Section A**, **four** questions from **Section B** and **two** questions from **Section C**.*
3. *Give only one answer / solution for each question.*
4. *Show your working. It may help you to get marks.*
5. *The diagrams in the questions provided are not drawn to scale unless stated.*
6. *The marks allocated for each question and sub-part of a question are shown in brackets.*
7. *A list of formulae is provided on pages 2 to 4.*
8. *A booklet of four-figure mathematical tables is provided.*
9. *You may use a non-programmable scientific calculator.*

This paper consists of 16 printed pages.

SULIT

2

The following formulae may be helpful in answering the questions. The symbols given are the ones commonly used.

ALGEBRA

1. $x = \frac{-b \pm \sqrt{b^2 - 4ac}}{2a}$
2. $a^m \times a^n = a^{m+n}$
3. $a^m \div a^n = a^{m-n}$
4. $(a^m)^n = a^{mn}$
5. $\log_a mn = \log_a m + \log_a n$
6. $\log_a \frac{m}{n} = \log_a m - \log_a n$
7. $\log_a m^n = n \log_a m$
8. $\log_a b = \frac{\log_c b}{\log_c a}$
9. $T_n = a + (n-1)d$
10. $S_n = \frac{n}{2}[2a + (n-1)d]$
11. $T_n = ar^{n-1}$
12. $S_n = \frac{a(r^n - 1)}{r - 1} = \frac{a(1 - r^n)}{1 - r}, r \neq 1$
13. $S_\infty = \frac{a}{1 - r}, |r| < 1$

CALCULUS

1. $y = uv, \frac{dy}{dx} = u \frac{dv}{dx} + v \frac{du}{dx}$
2. $y = \frac{u}{v}, \frac{dy}{dx} = \frac{v \frac{du}{dx} - u \frac{dv}{dx}}{v^2}$
3. $\frac{dy}{dx} = \frac{dy}{du} \times \frac{du}{dx}$
4. Area under a curve

$$= \int_a^b y \, dx$$
 or

$$= \int_a^b x \, dy$$
5. Volume generated

$$= \int_a^b \pi y^2 \, dx$$
 or

$$= \int_a^b \pi x^2 \, dy$$

STATISTICS

1. $\bar{x} = \frac{\sum x}{N}$
2. $\bar{x} = \frac{\sum fx}{\sum f}$
3. $\sigma = \sqrt{\frac{\sum (x - \bar{x})^2}{N}} = \sqrt{\frac{\sum x^2}{N} - \bar{x}^2}$
4. $\sigma = \sqrt{\frac{\sum f(x - \bar{x})^2}{\sum f}} = \sqrt{\frac{\sum fx^2}{\sum f} - \bar{x}^2}$
7. $\bar{I} = \frac{\sum W_i I_i}{\sum W_i}$
8. ${}^n P_r = \frac{n!}{(n-r)!}$
9. ${}^n C_r = \frac{n!}{(n-r)!r!}$
10. $P(A \cup B) = P(A) + P(B) - P(A \cap B)$
11. $P(X = r) = {}^n C_r p^r q^{n-r}, p + q = 1$

SULIT**3**

$$5. \quad m = L + \left(\frac{\frac{1}{2}N - F}{f_m} \right) c$$

$$6. \quad I = \frac{Q_1}{Q_o} \times 100$$

$$12. \quad \text{Mean, } \mu = np$$

$$13. \quad \sigma = \sqrt{npq}$$

$$14. \quad Z = \frac{x - \mu}{\sigma}$$

GEOMETRY

1. Distance

$$= \sqrt{(x_1 - x_2)^2 + (y_1 - y_2)^2}$$

2. Midpoint

$$(x, y) = \left(\frac{x_1 + x_2}{2}, \frac{y_1 + y_2}{2} \right)$$

3. A point dividing a segment of a line

$$(x, y) = \left(\frac{nx_1 + mx_2}{m+n}, \frac{ny_1 + my_2}{m+n} \right)$$

4. Area of triangle =

$$\frac{1}{2} |(x_1y_2 + x_2y_3 + x_3y_1) - (x_2y_1 + x_3y_2 + x_1y_3)|$$

$$5. \quad |r| = \sqrt{x^2 + y^2}$$

$$6. \quad \hat{r} = \frac{x\hat{i} + y\hat{j}}{\sqrt{x^2 + y^2}}$$

TRIGONOMETRY1. Arc length, $s = r\theta$ 2. Area of sector, $A = \frac{1}{2}r^2\theta$

$$3. \quad \sin^2 A + \cos^2 A = 1$$

$$4. \quad \sec^2 A = 1 + \tan^2 A$$

$$5. \quad \operatorname{cosec}^2 A = 1 + \cot^2 A$$

$$6. \quad \sin 2A = 2 \sin A \cos A$$

$$7. \quad \cos 2A = \cos^2 A - \sin^2 A$$

$$= 2 \cos^2 A - 1$$

$$= 1 - 2 \sin^2 A$$

$$8. \quad \sin(A \pm B) = \sin A \cos B \pm \cos A \sin B$$

$$9. \quad \cos(A \pm B) = \cos A \cos B \mp \sin A \sin B$$

$$10. \quad \tan(A \pm B) = \frac{\tan A \pm \tan B}{1 \mp \tan A \tan B}$$

$$11. \quad \tan 2A = \frac{2 \tan A}{1 - \tan^2 A}$$

$$12. \quad \frac{a}{\sin A} = \frac{b}{\sin B} = \frac{c}{\sin C}$$

$$13. \quad a^2 = b^2 + c^2 - 2bc \cos A$$

$$14. \quad \text{Area of triangle} = \frac{1}{2} ab \sin C$$

SULIT

4

Section A
Bahagian A

[40 marks]
[40 markah]

Answer **all** questions.
Jawab **semua** soalan.

- 1** Solve the following simultaneous equations :

Selesaikan persamaan serentak berikut :

$$y - 2x + 3 = 0 \quad [5 \text{ marks}]$$

$$x^2 + y^2 + xy - 10 = 0 \quad [5 \text{ markah}]$$

- 2** Given that $f(x) = 5x + 3$ and $g(x) = \frac{3}{2}x - 2$. Find

Diberi bahawa $f(x) = 5x + 3$ dan $g(x) = \frac{3}{2}x - 2$. Cari

(a) $f^{-1}(x)$ [1 mark]

$f^{-1}(x)$ [1 markah]

(b) $gf^{-1}(x)$ [2marks]

$gf^{-1}(x)$ [2markah]

(c) $h(x)$ such that $hf(x) = 3 + 10x$ [3 marks]

$h(x)$ supaya $hf(x) = 3 + 10x$ [3 markah]

- 3** (a) Sketch the graph of $y = 2 \cos 2x + 1$ for $0 \leq x \leq 2\pi$. [4 marks]

Lakar graf $y = 2 \cos 2x + 1$ untuk $0 \leq x \leq 2\pi$. [4 markah]

- (b) Hence using the same axes, sketch a suitable straight line to find the number of solutions for the equation $\pi \cos 2x - x = 0$ for $0 \leq x \leq 2\pi$.

State the number of solutions. [3 marks]

Seterusnya, dengan menggunakan paksi yang sama , lakar satu garis lurus yang sesuai untuk mencari bilangan penyelesaian bagi persamaan $\pi \cos 2x - x = 0$ untuk

$0 \leq x \leq 2\pi$. Nyatakan bilangan penyelesaian itu. [3 markah]

SULIT

5

4.

Diagram 1
Rajah 1

Diagram 1 shows the arrangement of the first four of an infinite series of similar rectangles. The length and width of the first rectangle is l cm and w cm respectively. The measurements of the length and width of each subsequent rectangle are half that of the previous one.

Rajah 1 menunjukkan empat buah segi empat tepat yang pertama bagi suatu siri infinit segi empat tepat yang serupa. Panjang dan lebar segi empat tepat yang pertama ialah l cm dan w cm masing-masing. Panjang dan lebar untuk segi empat tepat yang seterusnya adalah separuh ukuran segi empat tepat sebelumnya.

- (a) Show that the areas of the rectangle form a geometric progression and state the common ratio. [3 marks]
 Tunjukkan bahawa luas- luas segi empat tepat itu membentuk suatu jantang geometri. Nyatakan nisbah sepunyaanya. [3 markah]
- (b) Given that $l = 352$ cm and $w = 128$ cm,
 Diberi bahawa $l = 352$ cm dan $w = 128$ cm,
- (i) determine the number of rectangles with area greater than 11 cm², [3 marks]
 tentukan bilangan segi empat tepat yang luasnya lebih daripada 11 cm², [3 markah]
- (ii) find the sum to infinity of the areas, in cm² of the rectangles. [2 marks]
 cari hasil tambah hingga infiniti, luas segi empat tepat itu dalam cm². [2 markah]

5. Number of pupils
 Bilangan Murid

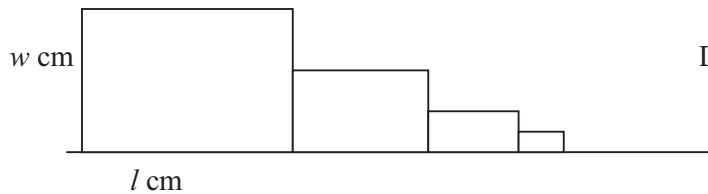
Diagram 2
Rajah 2

Diagram 2 shows a frequency polygon which represents the distribution of the scores obtained by 80 pupils in a test.

Rajah 2 menunjukkan suatu poligon kekerapan yang mewakili taburan markah yang di perolehi oleh 80 orang pelajar dalam satu ujian.

SULIT

6

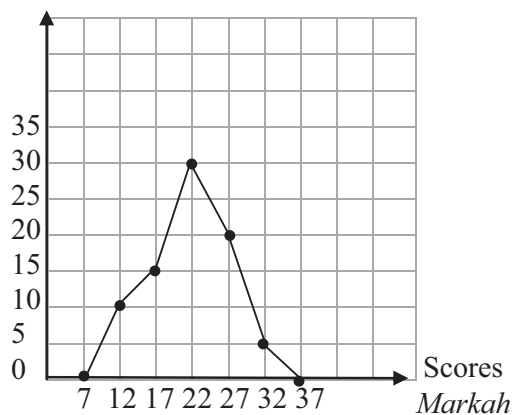
- (a) Complete the frequency distribution table below. [1 mark]
 Lengkapkan jadual taburan kekerapan di bawah. [1 markah]

Score Markah	10-14	15-19	20-24	25-29	30-34
Cumulative Frequency Kekerapan Longgokan					

- (b) Calculate the median score [3 marks]
 Hitung nilai markah median [3 markah]
- (c) Calculate the variance of the distribution. [3 marks]
 Hitung varians bagi taburan tersebut [3 markah]
6. Diagram 3 shows triangles OAB and OAC. The straight lines OB and AC intersect at point K such that $AK : AC = 1 : 3$. Given that $\vec{OA} = 3\mathbf{a}$ and $\vec{OC} = h\mathbf{b}$ where h is a constant.
 Rajah 3 menunjukkan segitiga-segitiga OAB dan OAC. Garis lurus OB dan AC bertemu di titik K di mana $AK : AC = 1 : 3$. Diberi bahawa $\vec{OA} = 3\mathbf{a}$ and $\vec{OC} = h\mathbf{b}$, dengan keadaan h ialah pemalar.

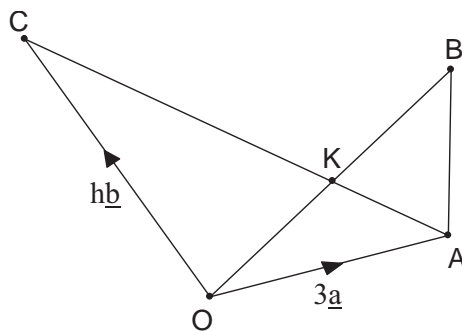

Diagram 3
Rajah 3

Find
Cari

- (a) \vec{AK} in terms of h, \mathbf{a} and \mathbf{b}
 \vec{AK} dalam sebutan h, \mathbf{a} and \mathbf{b}
- (b) \vec{OK} in terms of h, \mathbf{a} and \mathbf{b}
 \vec{OK} dalam sebutan h, \mathbf{a} and \mathbf{b}

[4 marks]
[4 markah]

Hence, if $\vec{KB} = 10\mathbf{a} + 5\mathbf{b}$, find the value of h. [3 marks]

Oleh itu, jika $\vec{KB} = 10\mathbf{a} + 5\mathbf{b}$, cari nilai h. [3 markah]

[3 markah]

SULIT

7

Section B
Bahagian B

[40 marks]
[40 markah]

Answer only **four** questions from this section
Jawab mana-mana **empat** soalan daripada bahagian ini

7. Given that $\int_0^2 f(x)dx = 17$, where $f(x)$ is a linear function.

Diberi $\int_0^2 f(x)dx = 17$, yang mana $f(x)$ ialah suatu fungsi linear.

- (a) Find the value of k when $\int_2^0 [f(x) + k] dx = 1$. [2marks]

Cari nilai k apabila $\int_2^0 [f(x) + k] dx = 1$. [2markah]

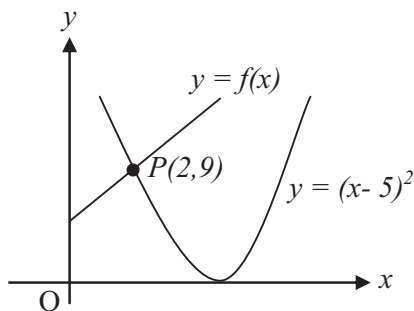

Diagram 4
Rajah 4

Diagram 4 shows the graph of the straight line $y = f(x)$ which intersects the curve $y = (x - 5)^2$ at point $P(2, 9)$.

Rajah 4 menunjukkan graf garis lurus $y = f(x)$ yang bersilang dengan lengkung $y = (x - 5)^2$ pada titik $P(2, 9)$.

- (b) Find the area bounded by the straight line $y = f(x)$, the curve $y = (x - 5)^2$, the x -axis and the y -axis. [4marks]
Cari luas yang dibatasi oleh garis lurus $y = f(x)$, lengkung $y = (x - 5)^2$, paksi- x dan paksi- y . [4 markah]
- (c) Calculate the volume generated in terms of π , when the area bounded by the line OP , the curve $y = (x - 5)^2$ and the x -axis is revolved through 360° about the x -axis. [4 marks]
Hitung isipadu yang dijanakan dalam sebutan π , apabila rantau yang dibatasi oleh garis lurus OP , lengkung $y = (x - 5)^2$ dan paksi- x dikisarkan melalui 360° pada paksi- x . [4 markah]

SULIT

8

8. Use graph paper to answer this question.
Gunakan kertas graf untuk menjawab soalan ini.

x	3	4	5	6	7	8
y	12.1	6.46	3.47	1.89	0.95	0.52

Table 5
Jadual 5

Table 5 shows the values of the variables x and y obtained from an experiment. Variables x and y are related by the equation $y = pq^{x-1}$, where p and q are constants.

Jadual 5 menunjukkan nilai-nilai pembolehubah x dan y , yang didapati daripada suatu ujikaji. Pembolehubah x dan y dikaitkan oleh persamaan $y = pq^{x-1}$, dengan keadaan p dan q adalah pemalar.

- (a) Using a scale of 2 cm to 1 unit on the $(x - 1)$ -axis and 2 cm to 0.2 unit on the log y -axis, plot $\log y$ against $(x - 1)$. Hence, draw the line of best fit. [5 marks]

Dengan menggunakan skala 2cm kepada 1 unit pada paksi- $(x - 1)$ dan 2cm kepada 0.2 unit pada paksi- $\log y$, plotkan $\log y$ melawan $(x - 1)$. Seterusnya, lukis satu garis lurus penyuaian terbaik. [5 markah]

- (b) From your graph in 8(a), find the value of
Daripada graf anda di 8(a), cari nilai

(i) p and of q
 p dan nilai q

(ii) x when $y = 5.0$.
 x apabila $y = 5.0$

[5 marks]

[5 markah]

SULIT

9

9. *Solution by scale drawing is not accepted.*
Penyelesaian secara lukisan berskala tidak diterima.

Diagram 6 shows a rectangle $PQRS$.

Rajah 6 menunjukkan sebuah segi empat tepat PQRS.

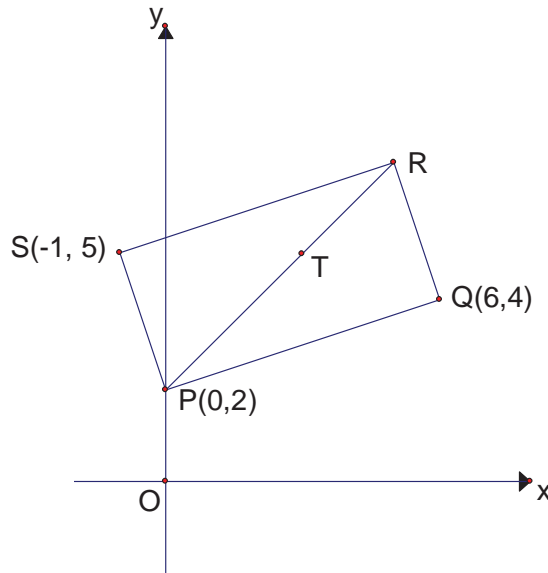

Diagram 6
Rajah 6

Given that the equation of the straight line PR is $y = 2 + x$. Point T lies on the straight line PR such that $PT : TR = 2 : 1$

Diberi persamaan garis lurus PR ialah $y = 2 + x$. Titik T terletak pada garis lurus PR dengan keadaan $PT : TR = 2 : 1$

(a) Find
Cari,

- | | |
|--|-----------------------------|
| (i) the equation of the straight line SR
<i>persamaan garis lurus SR</i> | [2 marks]
[2 markah] |
| (ii) the coordinates of T
<i>koordinat titik T,</i> | [4 marks]
[4 markah] |
| (iii) the area of triangle PST
<i>luas segitiga PST</i> | [2 marks]
[2 markah] |

- (b) A point M moves such that its distance from point S is always 5 units. Find the equation of the locus of M .
Suatu titik M bergerak dengan dengan keadaan jaraknya dari titik S ialah sentiasa 6 unit. Cari persamaan lokus titik M .
- [2 marks]
[2 markah]

SULIT

10

10.

Diagram 7
Rajah 7

Diagram 7 shows two circles with centres at A and B which intersect each other at points C and D. AC and AD are tangents to the circle with centre B.

Given that AB is 6 cm and $\angle CAD = \frac{\pi}{3}$ radian.

Rajah 7 menunjukkan dua buah bulatan yang berpusat A dan B dan bersilang satu sama lain di C dan D. AC dan AD adalah garis tangen kepada bulatan berpusat B. Diberi AB ialah 6 cm dan $\angle CAD$ ialah $\frac{\pi}{3}$ radian.

[Use $\pi = 3.142$. Give your answers correct to three decimal places]

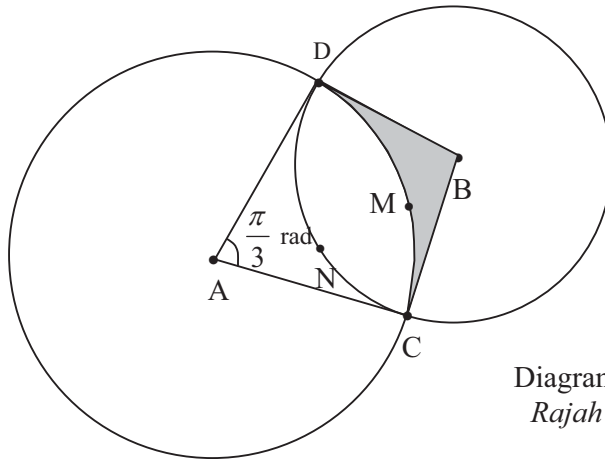
[Guna $\pi = 3.142$. Beri jawapan anda betul kepada tiga tempat perpuluhan]

Calculate

Hitung

- | | |
|--|-----------------------------|
| (a) the length of AC, in cm
<i>panjang AC, dalam cm</i> | [2 marks]
[2 markah] |
| (b) length of arc DNC, in cm
<i>panjang lengkok DNC, dalam cm</i> | [3 marks]
[3 markah] |
| (c) the area of sector ADMC, in terms of π
<i>luas sektor ADMC, dalam sebutan π</i> | [2 marks]
[2 markah] |
| (d) the area of the shaded region, in terms of π
<i>luas kawasan berlorek, dalam sebutan π</i> | [3 marks]
[3 markah] |

SULIT

11

- 11 (a) Given that 65% of the candidates who sat for a particular examination passed. If 9 candidates are chosen at random from the candidates who sat for the examination, find the probability that

Diberi bahawa, 65% daripada calon yang menduduki suatu peperiksaan tertentu telah lulus. Jika 9 calon dipilih secara rawak daripada calon yang menduduki peperiksaan itu, cari kebarangkalian bahawa

- (i) exactly 6 candidates passed,
tepat 6 orang calon lulus,
- (ii) at least 2 candidates failed.
sekurang-kurangnya 2 orang calon gagal.

[5 marks]

[5 markah]

- (b) The time taken to produce a souvenir are normally distributed with a mean of 30 minutes and a standard deviation of 5 minutes. Find the probability of producing a souvenir

Masa yang diambil untuk menghasilkan satu cenderamata adalah mengikut taburan normal dengan min 30 minit dan sisihan piawai 5 minit. Cari kebarangkalian menghasilkan satu cenderamata dalam tempoh

- (i) in not more than 35 minutes,
tidak melebihi 35 minit,
- (ii) between 15 and 25 minutes.
antara 15 dan 25 minit.

[5 marks]

[5 markah]

SULIT

12

Section C
Bahagian C

[20 marks]
[20 markah]

Answer any **two** questions from this section.
Jawab mana-mana **dua** soalan daripada bahagian ini.

12. Table 2 shows the prices and the prices indices of five commodities A, B, C, D and E.
Jadual 2 menunjukkan harga dan indeks harga bagi lima komoditi A, B, C, D dan E.

Commodity <i>Komoditi</i>	Price (RM) for year <i>Harga (RM) bagi tahun</i>		Price index for year 2010 based on year 2005 <i>Indeks harga pada tahun 2010 berasaskan tahun 2005</i>
	2005	2010	
A	2.00	2.50	125
B	4.50	5.25	y
C	x	2.50	175
D	5.00	7.50	150
E	4.00	z	95

Table 8

Jadual 8

Diagram 9 shows a bar chart indicating the monthly expenditure (in hundreds RM) of a family for the *commodities above for the year 2005*.

Rajah 9 ialah carta bar yang menunjukkan perbelanjaan bulanan (dalam ratus RM) sebuah keluarga bagi komoditi-komoditi di atas dalam tahun 2005.

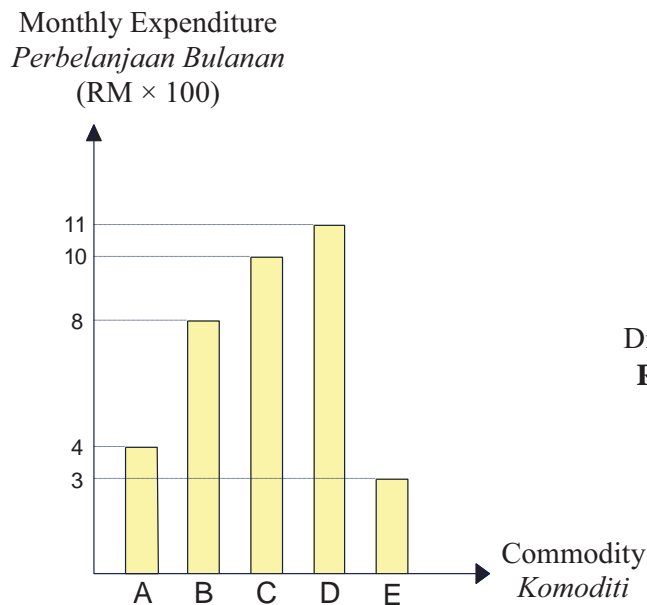

Diagram 9
Rajah 9

SULIT

13

- (a) Find the values of x , y and z . [3 marks]
Cari nilai x , y dan z . [3 markah]
- (b) Calculate the composite index for the expenditure of the commodities in the year 2010 based on the year 2005. [2 marks]
Hitung indeks gubahan bagi perbelanjaan komoditi-komoditi tersebut pada tahun 2010 berasaskan tahun 2005. [2 markah]
- (c) Calculate the total monthly expenditure for the commodities in the year 2010. [3 marks]
Hitung jumlah perbelanjaan bagi komoditi-komoditi tersebut pada tahun 2010. [3 markah]
- (d) If the indices of the commodities is expected to increase by 30% from the year 2010 to the year 2015, calculate the composite index for the year 2015 based on the year 2005. [2 marks]
Jika indeks komoditi-komoditi tersebut dijangka meningkat 30% dari tahun 2010 ke tahun 2015, hitung indeks gubahan tahun 2015 berasaskan tahun 2005. [2 markah]

- 13 Diagram 10 shows a quadrilateral $PQRS$.
Rajah 10 menunjukkan sebuah sisi empat $PQRS$.

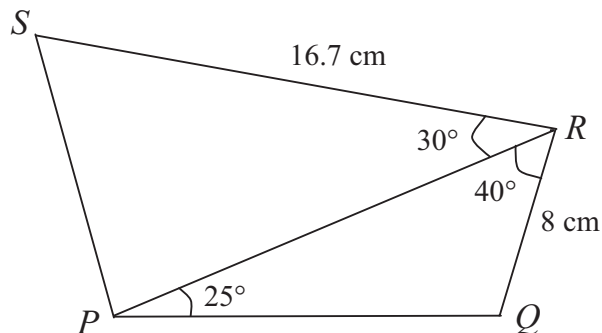

Diagram 10
 Rajah 10

- (a) Calculate the length, in cm, of
Hitung panjang, dalam cm, bagi
- (i) PR ,
 (ii) PS . [5 marks]
 [5 markah]
- (b) Point P' lies on PR such that $PS = P'S$. Calculate
Titik P' terletak pada PR dengan keadaan $PS = P'S$. Hitung
- (i) $\angle RPS$,
 (ii) the area, in cm^2 , of $\triangle PP'S$.
luas, dalam cm^2 , bagi $\triangle PP'S$. [5 marks]
 [5 markah]

SULIT

14

- 14 Use graph paper to answer this question.
Gunakan kertas graf untuk menjawab soalan ini.

A furniture workshop has 2 workers, A and B , doing the job of assembling and then painting desks. The time taken by these workers is as tabulated in Table 11.

Suatu kilang perabot menggaji 2 orang pekerja, A dan B , untuk memasang dan mengecat meja. Masa yang diambil oleh pekerja adalah dijadualkan di Jadual 11.

Worker Pekerja	Time taken (minutes) Masa diambil (minit)	
	Assemble Memasang	Paint Mengecat
A	105	60
B	120	30

Table 11
Jadual 11

In a week, worker A can complete x desks, while worker B complete y desks. These two workers work under the following constraints:

Dalam suatu minggu, pekerja A dapat menyiapkan x buah meja, manakala pekerja B menyiapkan y buah meja. Kedua-dua orang pekerja itu bekerja berdasarkan kekangan berikut:

- I The total time taken by the two workers does not exceed 110 hours.
Jumlah masa yang diambil oleh dua orang pekerja itu tidak melebihi 110 jam.
 - II The minimum total time by the two workers for assembling the desks is 14 hours.
Jumlah masa minimum yang diambil oleh dua pekerja untuk memasang meja ialah 14 jam.
 - III The number of desks completed by A must not exceed by 20 that completed by B .
Bilangan buah meja yang disiapkan oleh A tidak melebihi 20 buah bilangan yang disiapkan oleh B .
- (a) Write three inequalities, other than $x \geq 0$ and $y \geq 0$, which satisfy all the above constraints. [3 marks]
Tuliskan tiga ketaksamaan, selain $x \geq 0$ dan $y \geq 0$, yang memenuhi semua kekangan di atas. [3 markah]
 - (b) Using a scale of 2 cm to 5 desks on the both axes, construct and shade the region R which satisfies all the above constraints. [3 marks]
Dengan menggunakan skala 2 cm kepada 5 meja pada kedua-dua paksi, bina dan lorekkan rantau R yang memenuhi semua kekangan di atas. [3 markah]
 - (c) Use your graph from (b) to answer the following questions:.
Guna graf anda dari (b) untuk menjawab soalan berikut:
 - (i) Find the range of the number of desks which completed by worker B if worker A completed 6 desks for that particular week.
Cari julat bagi bilangan meja yang disiapkan oleh pekerja B jika pekerja A menyiapkan 6 buah meja pada minggu yang tertentu.

SULIT

15

- (ii) The profit for each desk sold is RM 12. Assuming that all the desks made by A and B for that particular week are sold, find the maximum total profit netted.
Keuntungan bagi sebuah meja ialah RM 12. Anggapan bahawa semua meja yang disediakan oleh A dan B bagi hari yang tertentu telah dijual, cari jumlah keuntungan maximum.

[4 marks]

[4 markah]

15. A particle moves along a straight line and passes through a fixed point O . Its velocity, $v \text{ ms}^{-1}$, is given by $v = 6 + 3t - 3t^2$, where t is the time, in seconds, after passing through O . The particle stops instantaneously at a point R .

[Assume motion to the right is positive]

Suatu zarah bergerak di sepanjang suatu garis lurus dan melalui satu titik tetap O .

Halajunya $v \text{ ms}^{-1}$ diberi oleh $v = 6 + 3t - 3t^2$ di mana t ialah masa dalam saat. selepas melalui O . Zarah itu berhenti seketika di suatu titik R .

(Anggapkan gerakan ke arah kanan sebagai positif)

Find

Cari

- (a) the initial velocity [1 mark]
halaju awalnya [1 markah]
- (b) the acceleration, in ms^{-2} , of the particle at R , [3 mark]
pecutan dalam ms^{-2} bagi zarah itu di R [3 markah]
- (c) the maximum velocity, in ms^{-1} , of the particle, [2 marks]
halaju maksimum, dalam ms^{-1} bagi zarah itu [2 markah]
- (d) the total distance, in m , travelled by the particle in the first 4 seconds, after passing through O . [4 marks]
jumlah jarak dalam m , yang dilalui oleh zarah itu dalam 4 saat pertama selepas melalui O . [4 markah]

END OF QUESTION PAPER

KERTAS SOALAN TAMAT

SULIT

16

NO. KAD PENGENALAN

--	--	--	--	--	--	--	--	--	--	--	--	--	--	--	--	--	--	--	--

ANGKA GILIRAN

--	--	--	--	--	--	--	--	--	--

Arahan Kepada Calon

- 1 Tulis **nombor kad pengenalan** dan **angka giliran** anda pada ruang yang disediakan.
- 2 Tandakan (\checkmark) untuk soalan yang dijawab.
- 3 Ceraikan helaian ini dan ikat sebagai muka hadapan bersama-sama dengan buku jawapan.

<i>Kod Pemeriksa</i>				
Bahagian	Soalan	Soalan Dijawab	Markah Penuh	Markah Diperoleh (Untuk Kegunaan Pemeriksa)
A	1		5	
	2		6	
	3		7	
	4		8	
	5		7	
	6		7	
B	7		10	
	8		10	
	9		10	
	10		10	
	11		10	
C	12		10	
	13		10	
	14		10	
	15		10	
Jumlah				

SULIT

17

ADDITIONAL MATHS - PAPER 2					
1		$y = 2x - 3$ or $x = \frac{y - 3}{2}$	P1	5	
		Substitute x or y into $x^2 + y^2 + xy - 10 = 0$	K1		
		$x = \frac{-(-15) \pm \sqrt{(-15)^2 - 4(7)(-1)}}{2(7)}$	K1		
		or $y = \frac{-12 \pm \sqrt{12^2 - 4(7)(-31)}}{2(7)}$			
		$x = 2.208$ and -0.06471	N1		
	$y = 1.415$ and -3.129	N1			
2	2a	$\frac{x - 3}{5}$	P1	6	
	2b	$\frac{3}{2} \left(\frac{x - 3}{2} \right) - 2$	K1		
		$\frac{3x - 29}{10}$	N1		
	2c	$3 + 10 \left(\frac{y - 3}{5} \right)$	$2(5x + 3) - 3$		K1
		$2y - 3$			K1
$h(x) = 2x - 3$		N1			
3	3a	<p>Cosine graph shape Amplitude = 4 2 cycles Translated 1 unit and passing through $(0, 3), (2\pi, 3)$</p>	P1 P1 P1 P1	4	
	3b	$y = \frac{2x}{\pi} + 1$	N1	3	
		Draw the line $y = \frac{2x}{\pi} + 1$	L1		
No of solutions = 3		N1			
4	4a	$lw, \frac{1}{2}l \left(\frac{1}{2}w \right), \frac{1}{2} \left(\frac{1}{2}l \right) \left(\frac{1}{2} \right) \left(\frac{1}{2}w \right), \dots$	P1	3	
		$lw, \frac{1}{4}lw, \frac{1}{16}lw, \dots, r = \frac{1}{4}$	K1		
		A GP with $r = \frac{1}{4}$	N1		

4	4b(i)	a = 352(128) or equivalent						P1	5
		$352(128)\left(\frac{1}{4}\right)^{n-1} > 11$						K1	
		No. of rectangles = 6						N1	
	4b(ii)	$S_{\infty} = \frac{352(128)}{1 - \frac{1}{4}}$						K1	
$60074\frac{2}{3}$						N1			
5	5a	10 - 14	15 - 19	20 - 24	25 - 29	30 - 34		P1	7
		10	25	55	75	80			
	5b	L = 19.5 or F = 25 or $f_m = 30$						P1	
		$19.5 + \left(\frac{40-25}{30}\right) \times 5$						K1	
		22						N1	
	5c	Mean = 21.688						P1	
$\frac{39995}{80} - 21.688^2$						K1			
						29.568	N1		
6	6a	$\vec{AC} = -3\mathbf{a} + h\mathbf{b}$						K1	7
		$\frac{1}{3}(-3\mathbf{a} + h\mathbf{b})$ or $-\mathbf{a} + \frac{h}{3}\mathbf{b}$						N1	
	6b	$3\mathbf{a} + \frac{1}{3}(-3\mathbf{a} + h\mathbf{b})$						K1	
		$2\mathbf{a} + \frac{h}{3}\mathbf{b}$						N1	
		$10\mathbf{a} + 5\mathbf{b} = m(2\mathbf{a} + \frac{h}{3}\mathbf{b})$ where m is a constant						K1	
		m = 5						N1	
h = 3						N1			
7	7a	$-17 + [kx]_2^0 = 1$						K1	10
		$k = -9$						N1	
	7b	$\frac{(x-5)^3}{3}$						P1	
		$\int_0^2 f(x)dx + \int_2^5 (x-5)^2 dx$						K1	
		$17 + \left(\frac{0^3}{3} - \frac{(-3)^3}{3}\right)$						K1	
		26						N1	
7c	$\frac{1}{3}\pi(9^2)2$ or $\pi \int_0^2 \left(\frac{9}{2}x\right)^2 dx$						P1		

		$\pi \int_0^2 \left(\frac{9}{2}x\right)^2 dx + \pi \int_2^5 (x-5)^4 dx$ or equivalent	K1	
7	7c	$\pi \left[\frac{81}{4} \times \frac{x^3}{3} \right]_0^2 + \pi \left[\frac{(x-5)^5}{5} \right]_2^5$	K1	
		$102\frac{3}{5}\pi$	N1	
8	8a (refer a diagram)	$\log y$ 1.08 0.81 0.54 0.28 -0.02 -0.28	P1	10
		Using the correct, uniform scale and axes	P1	
		All points plotted correctly	P1	
		Line of best fit	P1	
		$\log y = (x-1)\log q + \log p$	P1	
	8b(i)	Use $\log q = *m$ or $\log p = *c$	K1	
		$q = 0.53$	N1	
		$p = 43.65$	N1	
	8b(ii)	Use $\log y = 0.70$ to find $x-1$ from the graph	K1	
		$x = 4.40$	N1	
9	9a(i)	$y-5 = \frac{1}{3}(x+1)$ or $5 = \frac{1}{3}(-1) + c$	K1	
		$3y = x + 16$ or equivalent	N1	
	9a(ii)	$\left(\frac{5}{2}, \frac{9}{2}\right)$	P1	
		R(5,7)	P1	
		$\left(\frac{2 \times 5 + 1 \times 0}{3}, \frac{2 \times 7 + 1 \times 2}{3}\right)$	K1	
		$\left(\frac{10}{3}, \frac{16}{3}\right)$	N1	
	9a(iii)	$\frac{1}{2} \left 0 - \frac{16}{3} + \frac{20}{3} - \left(-2 + \frac{50}{3} + 0\right) \right $ or equivalent	K1	
		$\frac{20}{3}$	N1	
	9b	$\sqrt{(x+1)^2 + (y-5)^2} = 5$	K1	
		$x^2 + y^2 + 2x - 10y + 1 = 0$	N1	
10	10a	$6 \cos \frac{\pi}{6}$ or equivalent	K1	
		5.196 or $3\sqrt{3}$	N1	
	10b	BC = 3	P1	
		$3 \times \frac{2\pi}{3}$	K1	
		6.284	N1	
	10c	$\frac{1}{2}(5.196)^2 \times \frac{\pi}{3}$	K1	
		14.138	N1	
	10d	$2 \times \frac{1}{2} \times 5.196 \times 3$	K1	

SULIT

20

		$2 \times \frac{1}{2} \times 5.196 \times 3 - 14.138$	K1	
		1.450	N1	
11	11a(i)	${}^9C_6(0.65)^6(0.35)^3$	K1	10
		0.2716	N1	
	11a(ii)	${}^9C_1(0.65)^8(0.35)^1$ or ${}^9C_0(0.65)^9(0.35)^0$	P1	
		$1 - 0.10037 - 0.02071$	K1	
	11b(i)	$P(Z \leq \frac{35-30}{5})$	K1	
		0.8413	N1	
	11b(ii)	$P(\frac{15-30}{5} < Z < \frac{25-30}{5})$	K1	
		$0.15866 - 0.00135$	K1	
		0.1573	N1	
12	12a	$y = 116.67$	P1	10
		$x = 1.43$	P1	
		$z = 3.80$	P1	
	12b	$\frac{125 \times 4 + 116.67 \times 8 + 175 \times 10 + 150 \times 11 + 95 \times 3}{4 + 8 + 10 + 11 + 3}$	K1	
		142.18	N1	
	12c	$\frac{142.18 \times 3600}{100}$	K1	
		51118.48	N1	
	12d	$\frac{142.18 \times 130}{100}$	K1	
184.83		N1		
13	13a(i)	$\angle PQR = 115^\circ$	P1	10
		$\frac{8 \sin 115^\circ}{\sin 25^\circ}$	K1	
		17.16	N1	
	13a(ii)	$PS^2 = 16.7^2 + 17.16^2 - 2(16.7)(17.16)\cos 30^\circ$	K1	
		8.775	N1	
	13b(i)	$\frac{16.7 \times \sin 30^\circ}{8.775}$	K1	
		$\angle RPS = 72.09^\circ$	N1	
	13b(ii)	$\angle PSP' = 35.82^\circ$	P1	
$\frac{1}{2}(8.775)^2 \sin 35.82^\circ$		K1		
		22.53	N1	

14	14a	<p>G: (0.00, 44.00)</p> <p>$r(y) = 6$</p> <p>$f(x) = -1.1x + 44$</p> <p>R</p> <p>$h(x) = -\left(\frac{7}{8}\right)x + 7$</p> <p>$g(x) = x - 20$</p>		
		$11x + 10y \leq 440$ or equivalent	N1	10
		$7x + 8y > 56$ or equivalent	N1	
		$x - y \leq 20$ or equivalent	N1	
	14b	Draw correctly at least straight line from *the inaequalities which involves x and y	K1	
		Draw all correctly all three *straight lines	N1	
		Shade the correct region R	N1	
	14c(i)	$2 \leq y \leq 37$	N1	
	14c(ii)	Maximum point (0, 44)	K1	
		$12(0) + 12(44)$ or $12(0 + 44)$ or $12(44)$	K1	
RM528		N1		
15	15a	6 cms^{-1}	N1	10
	15b	Accelerataion = $3 - 6t$	K1	
		$(t - 2)(t + 1) = 0$	K1	
		-9	N1	
	15c	$t = \frac{1}{2}$	K1	
		$6\frac{3}{4}$ or equivalent	N1	
	15d	$s = 6t + \frac{3t^3}{2} - t^3$	K1	
		$6(2) + \frac{3(2)^3}{2} - (2)^3$ or $6(4) + \frac{3(4)^3}{2} - (4)^3$	K1	
		$10 + -26 $ or $10 + 10 + -16 $	K1	
		36	N1	